

OPERATOR'S MANUAL

INCLUDING: OPERATION, INSTALLATION & MAINTENANCE

81883X

RELEASED: 9-21-99

REVISED: 2-6-04

(REV. M)

1/2" DIAPHRAGM PUMP 1:1 RATIO



**READ THIS MANUAL CAREFULLY BEFORE INSTALLING,
OPERATING OR SERVICING THIS EQUIPMENT.**

It is the responsibility of the employer to place this information in the hands of the operator. Keep for future reference.

SERVICE KITS

Refer to "Model Description Chart" to match the pump material options.
862004 for Air Section repair (see page 8).
862040 for replacement of diaphragms (see pages 4 and 6).
862041 for replacement of diaphragms (see page 6).
862042 for replacement of diaphragms (see page 6).
862045 for replacement of balls and seats (see pages 4 and 6).
862046 (optional) for replacement of balls and seats (see pages 4 and 6).
862047 for replacement of balls and seats (see pages 4 and 6).

PUMP DATA

Models see "Model Description Chart".
Pump Type Air Operated Double Diaphragm.
Material see "Model Description Chart".
Weight . models 818830, 818834 14.6 lbs (6.6 kgs)
 models 818831, 818836 8.8 lbs (4.0 kgs)
 models 818832, 818833, 818835 . 7.2 lbs (3.3 kgs)
 models 818837, 818838 8.36 lbs (3.8 kgs)
Maximum Air Inlet Pressure 100 p.s.i. (6.9 bar)
Maximum Material Inlet Pressure 10 p.s.i. (0.69 bar)
Maximum Outlet Pressure 100 p.s.i. (6.9 bar)
Air Consumption 1 c.f.m. / gallon (approx.)
Maximum Flow Rate (flooded inlet)
818830, 818832, 818833, 818836, 818837 13 g.p.m. (49.2 l.p.m.)
818831, 818834, 818835, 818838 7 g.p.m. (26.5 l.p.m.)
Displacement / Cycle @ 100 p.s.i.g.
818830, 818832, 818833, 818836, 818837 0.040 gal. (0.15 lit.)
818831, 818834, 818835, 818838 0.022 gal. (0.08 lit.)
Maximum Particle Size 3/32" dia. (2.4 mm)
**Maximum Temperature Limits (based on the materials of the following
items: Fluid Caps / Manifolds, Seats, Diaphragms, Seals, Balls)**
E.P.R. -60° to 280° F (-51° to 138° C)
Groundable Acetal 10° to 180° F (-12° to 82° C)
Polypropylene 35° to 150° F (2° to 66° C)
Polyurethane 10° to 150° F (-12° to 66° C)
Santoprene® -40° to 225° F (-40° to 107° C)
T.F.E. (Teflon®) 40° to 225° F (4° to 107° C)
Dimensional Data see pages 10 and 11.
Noise Level @ 70 p.s.i., 60 c.p.m. 71.1 db(A)*

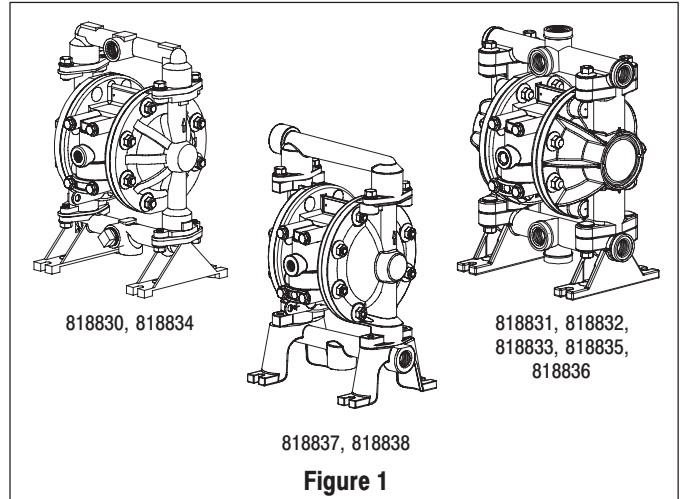

MODEL DESCRIPTION CHART

81883 X	
FLUID CAP / MANIFOLD MATERIAL, BALL MATERIAL	
0 - Stainless Steel, Stainless Steel (Standard Stroke)	
1 - Groundable Acetal, Stainless Steel (Short Stroke)	
2 - Polypropylene, Santoprene (Standard Stroke)	
3 - Polypropylene, Stainless Steel (Standard Stroke)	
4 - Stainless Steel, Stainless Steel (Short Stroke)	
5 - Polypropylene, Santoprene (Short Stroke)	
6 - Groundable Acetal, Stainless Steel (Standard Stroke)	
7 - Aluminum, Stainless Steel (Standard Stroke)	
8 - Aluminum, Stainless Steel (Short Stroke)	
THREADS - 1/2 - 14 N.P.T.F. - 1	
INLET & OUTLET MANIFOLD - Single piece	
CENTER BODY MATERIAL - Polypropylene	
SEAT MATERIAL - 316 Stainless Steel	
BALL MATERIAL - Stainless Steel	
- T.F.E. (Teflon) (optional kit)	
- Santoprene	
DIAPHRAGM MATERIAL - T.F.E. (Teflon)	
- Santoprene	

* The pump sound pressure levels published here have been updated to an Equivalent Continuous Sound Level (L_{Aeq}) to meet the intent of ANSI S1.13-1971, CAGI-PNEUROP S5.1 using four microphone locations.

BINKS®

North American Office
Industrial Finishing
195 Internationale Blvd
Glendale Heights, IL 60139
Tel. 630-237-5000 Fax 630-237-5011

International Office
Industrial Finishing
Ringwood Road, Bournemouth
Dorset, BH11 9LH, England
Tel. 0 1202 571111 Fax 0 1202 593883

OPERATING AND SAFETY PRECAUTIONS

READ, UNDERSTAND, AND FOLLOW THIS INFORMATION TO AVOID INJURY AND PROPERTY DAMAGE.



⚠ WARNING EXCESSIVE AIR PRESSURE. Can cause personal injury, pump damage or property damage.

- Do not exceed the maximum inlet air pressure as stated on the pump model plate.
- Be sure material hoses and other components are able to withstand fluid pressures developed by this pump. Check all hoses for damage or wear. Be certain dispensing device is clean and in proper working condition.

⚠ WARNING STATIC SPARK. Can cause explosion resulting in severe injury or death. Ground pump and pumping system.

- Sparks can ignite flammable material and vapors.
- The pumping system and object being sprayed must be grounded when it is pumping, flushing, recirculating or spraying flammable materials such as paints, solvents, lacquers, etc. or used in a location where surrounding atmosphere is conducive to spontaneous combustion. Ground the dispensing valve or device, containers, hoses and any object to which material is being pumped.
- 818831 Groundable Acetal pumps: Use the pump grounding screw provided. Connect a 12 ga. (min.) wire (kit is included) to a good earth ground source.
- Secure pump, connections and all contact points to avoid vibration and generation of contact or static spark.
- Consult local building codes and electrical codes for specific grounding requirements.
- After grounding, periodically verify continuity of electrical path to ground. Test with an ohmmeter from each component (e.g., hoses, pump, clamps, container, spray gun, etc.) to ground to insure continuity. Ohmmeter should show 0.1 ohms or less.
- Submerge the outlet hose end, dispensing valve or device in the material being dispensed if possible. (Avoid free streaming of material being dispensed.)
- Use hoses incorporating a static wire.
- Use proper ventilation.
- Keep inflammables away from heat, open flames and sparks.
- Keep containers closed when not in use.

⚠ WARNING Pump exhaust may contain contaminants. Can cause severe injury. Pipe exhaust away from work area and personnel.

- In the event of a diaphragm rupture, material can be forced out of the air exhaust muffler.
- Pipe the exhaust to a safe remote location when pumping hazardous or inflammable materials.
- Use a grounded 3/8" minimum i.d. hose between the pump and the muffler.

⚠ WARNING HAZARDOUS PRESSURE. Can result in serious injury or property damage. Do not service or clean pump, hoses or dispensing valve while the system is pressurized.

- Disconnect air supply line and relieve pressure from the system by opening dispensing valve or device and / or carefully and slowly loosening and removing outlet hose or piping from pump.

⚠ WARNING HAZARDOUS MATERIALS. Can cause serious injury or property damage. Do not attempt to return a pump to the factory or service center that contains hazardous material. Safe handling practices must comply with local and national laws and safety code requirements.

- Obtain Material Safety Data Sheets on all materials from the supplier for proper handling instructions.

⚠ CAUTION Verify the chemical compatibility of the pump wetted parts and the substance being pumped, flushed or recirculated. Chemical compatibility may change with temperature and concentration of the chemical(s) within the substances being pumped, flushed or circulated. Consult Bink's representative for information on chemical compatibility.

⚠ CAUTION Maximum temperatures are based on mechanical stress only. Certain chemicals will significantly reduce maximum safe operating temperature. Consult Bink's representative for information on chemical compatibility. Refer to PUMP DATA on page 1 of this manual.

⚠ CAUTION Be certain all operators of this equipment have been trained for safe working practices, understand it's limitations, and wear safety goggles / equipment when required.

⚠ CAUTION Do not use the pump for the structural support of the piping system. Be certain the system components are properly supported to prevent stress on the pump parts.

- Suction and discharge connections should be flexible connections (such as hose), not rigid piped, and should be compatible with the substance being pumped.

⚠ CAUTION Prevent unnecessary damage to the pump. Do not allow pump to operate when out of material for long periods of time.

- Disconnect air line from pump when system sits idle for long periods of time.

⚠ CAUTION Use only genuine Bink's replacement parts to assure compatible pressure rating and longest service life.

NOTICE Install the pump in the vertical position. The pump may not prime properly if the balls do not check by gravity upon start-up.

NOTICE Re-torque all fasteners before operation. Creep of housing and gasket materials may cause fasteners to loosen. Re-torque all fasteners to insure against fluid or air leakage.

⚠ WARNING = Hazards or unsafe practices which could result in severe personal injury, death or substantial property damage.

⚠ CAUTION = Hazards or unsafe practices which could result in minor personal injury, product or property damage.

NOTICE = Important installation, operation or maintenance information.

GENERAL DESCRIPTION

The Bink's Diaphragm Pump offers high volume delivery even at low air pressure. Bink's pumps feature stall resistant design, modular air motor / fluid sections.

Air operated double diaphragm pumps utilize a pressure differential in the air chambers to alternately create suction and positive fluid pressure in the fluid chambers, ball checks insure a positive flow of fluid.

Pump cycling will begin as air pressure is applied and it will continue to pump and keep up with the demand. It will build and maintain line pressure and will stop cycling once maximum line pressure is reached (dispensing device closed) and will resume pumping as needed.

Models 818831 and 818836: The Acetal material used in these pumps contains Stainless Steel fibers. It's conductivity allows it to be connected to a suitable ground. A ground screw and ground wire kit is provided for this.

AIR AND LUBE REQUIREMENTS

- Use a filter capable of filtering out particles larger than 50 microns on the air supply. There is no lubrication required other than the "O" ring lubricant which is applied during assembly or repair.
- If lubricated air is present, make sure that it is compatible with the Nitrile "O" rings in the air motor section of the pump.

OPERATING INSTRUCTIONS

- Always flush the pump with a solvent compatible with the material being pumped if the material being pumped is subject to "setting up" when not in use for a period of time.
- Disconnect the air supply from the pump if it is to be inactive for a few hours.
- The outlet material volume is governed not only by the air supply but also by the material supply available at the inlet. The material supply tubing should not be too small or restrictive. Be sure not to use hose which might collapse.
- When the diaphragm pump is used in a forced-feed (flooded inlet) situation, it is recommended that a "Check Valve" be installed at the air inlet.
- Secure the diaphragm pump legs to a suitable surface to insure against damage by vibration.

MAINTENANCE

- Provide a clean work surface to protect sensitive internal moving parts from contamination from dirt and foreign matter during service disassembly and reassembly.
- Keep good records of service activity and include pump in preventive maintenance program.
- Service Kits are available to service three separate Diaphragm Pump functions: 1. AIR SECTION, 2. DIAPHRAGM SECTION, 3. BALL and SEAT SECTION.

PARTS LIST / 81883X FLUID SECTION

★ 862040 Diaphragm Repair Kits include: (standard for models 818830, 818837)	Item #	2	7	8	19	20	33		Grease Packet	Operator's Manual
	Qty	1	2	2	4	2	4		1	1
● 862041 Diaphragm Repair Kits include: (standard for models 818834, 818838)	Item #	2	3	7	19	20	33	64	Grease Packet	Operator's Manual
	Qty	1	2	2	4	2	4	2	1	1
□ 862045 Ball and Seat Repair Kits include: (stainless steel ball and seat)	Item #	19	20	21	22				Grease Packet	Operator's Manual
	Qty	4	2	4	4				1	1
◆ 862046 Ball and Seat Repair Kits include: (optional Teflon ball & stainless steel seat)	Item #	19	20	21	22				Grease Packet	Operator's Manual
	Qty	4	2	4	4				1	1
▲ 862047 Ball and Seat Repair Kits include: (optional Santoprene ball & stainless steel seat)	Item #	19	20	21	22				Grease Packet	Operator's Manual
	Qty	4	2	4	4				1	1

WETTED COMMON PARTS 818830, 818834, 818837, 818838

Item	Description (size in inches)	Qty	Part No.	[Mtl]
1	Connecting Rod	(1)	873035	[SS]
★ 2	"O" Ring (3/32" x 5/8" o.d.)	(1)		[B]
● 3	"O" Ring (1/16" x 9/16" o.d.) (models 818834, 818838)	(2)		[T]
5	Diaphragm Washer (2" o.d.)	(2)	873403	[GFN]
6	Diaphragm Washer (2" o.d.)	(2)	873287	[SS]
●★ 7	Diaphragm	(2)		[T]
★ 8	Diaphragm (models 818830, 818837)	(2)		[SP]
12	Washer (models 818837, 818838)	(4)		[A]
14	Flange Screw (5/16" - 18 x 3/4")	(2)		[SS]
15	Fluid Cap (models 818830, 818834)	(2)	873288	[SS]
	Fluid Cap (models 818837, 818838)	(2)	873427	[A]
▲◆□★ 19	"O" Ring (3/32" x 1-5/16" o.d.)	(4)		[T]
▲◆□ 21	Seat	(4)		[SS]
□ 22	Ball (3/4" diameter)	(4)		[SS]
	Ball (3/4" diameter)	(4)		[T]
	Ball (3/4" diameter)	(4)		[SP]
26	Flange Screw (5/16" - 18)	(8)		[SS]
43	Ground Strap	(1)		[SS]
57	Ground Kit Ass'y (not shown)	(1)	873067	
60	Manifold, Inlet (818830, 818834)	(1)	873037	[SS]
	Manifold, Inlet (818837, 818838)	(1)	873425	[A]
61	Manifold, Outlet (818830, 818834)	(1)	873036	[SS]
	Manifold, Outlet (818837, 818838)	(1)	873426	[A]
62	Flange Nut (5/16" - 18)	(16)		[SS]
63	Pipe Plug (1/2 - 14 N.P.T.)			
	(models 818830, 818834)	(1)	873430	[SS]
	(models 818837, 818838)	(1)	873431	[C]
● 64	"O" Ring (.210" x 4.576" o.d.) (models 818834, 818838)	(2)		[U]

MATERIAL CODE

[A]	= Aluminum
[B]	= Nitrile
[C]	= Carbon Steel
[GFN]	= Glass Filled Nylon
[SP]	= Santoprene
[SS]	= Stainless Steel
[T]	= Teflon
[U]	= Polyurethane

CROSS SECTION / 818830, 818834

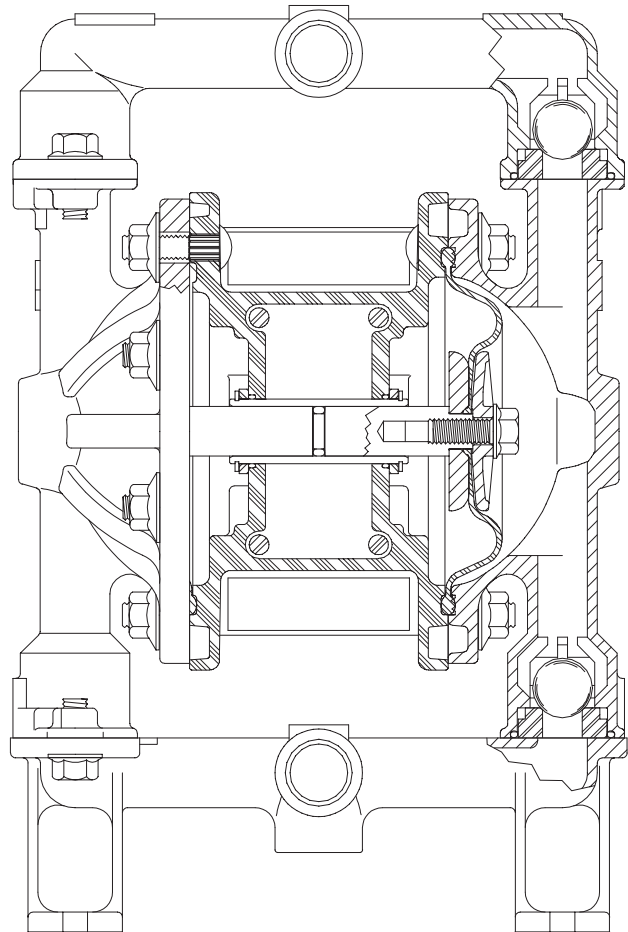
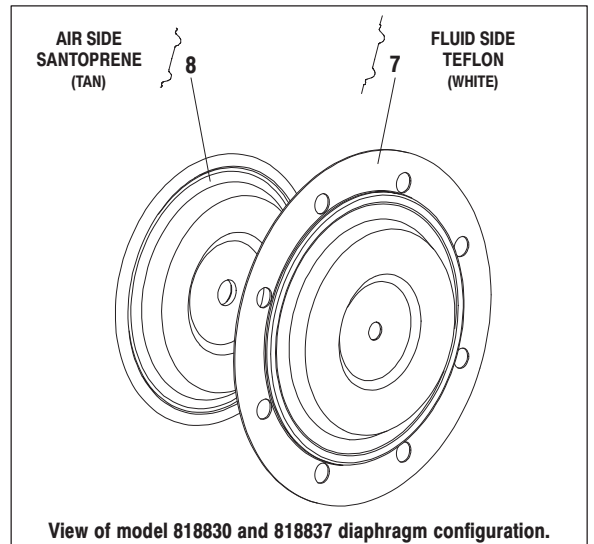
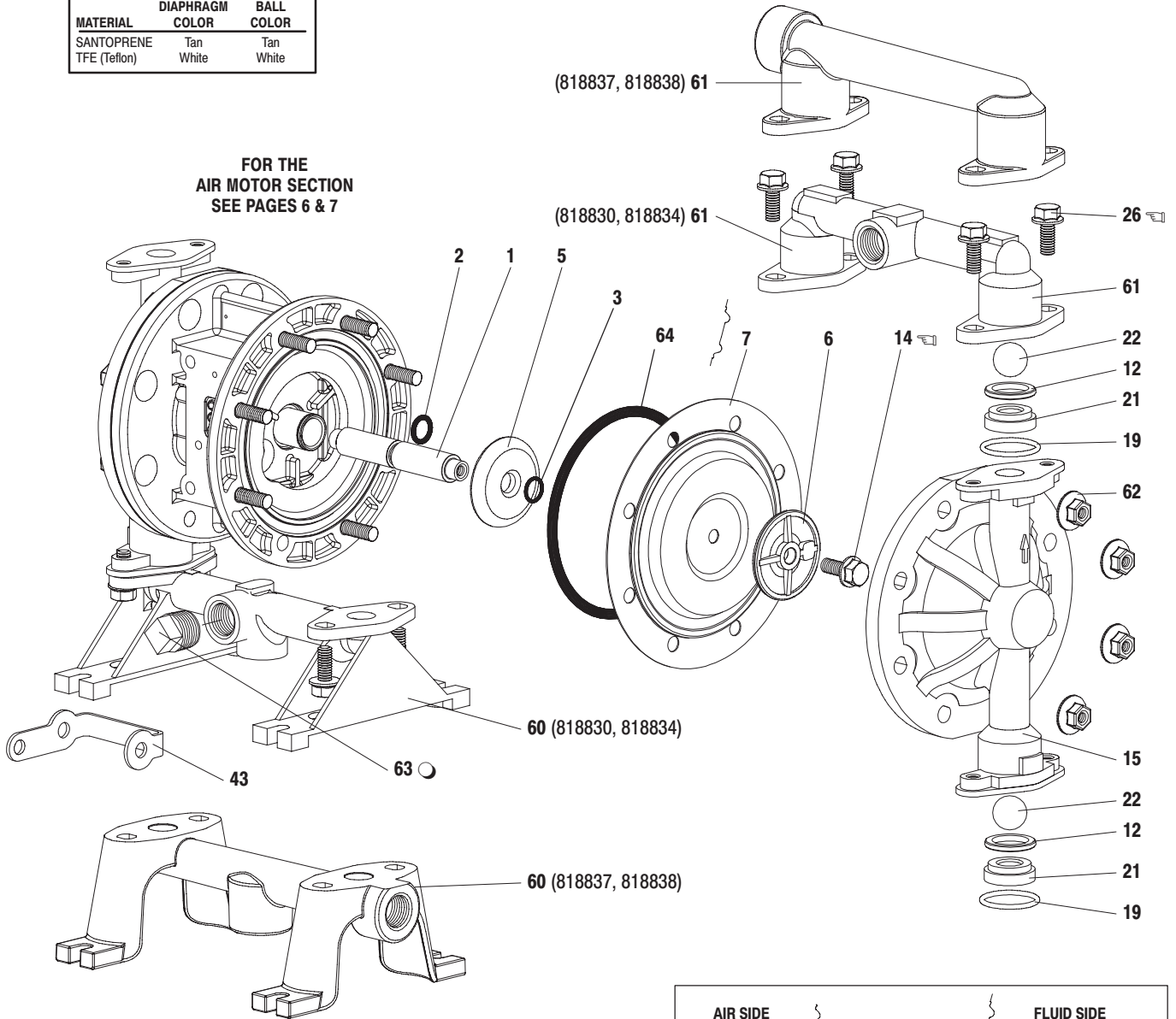

Figure 2

PARTS LIST / 81883X FLUID SECTION

COLOR CODE		
MATERIAL	DIAPHRAGM COLOR	BALL COLOR
SANTOPRENE	Tan	Tan
TFE (Teflon)	White	White

FOR THE
AIR MOTOR SECTION
SEE PAGES 6 & 7



TORQUE REQUIREMENTS

NOTE: DO NOT OVERTIGHTEN FASTENERS

(14) Bolt 95 - 105 in. lbs (10.7 - 11.9 Nm).

(26) Bolts 50 - 60 in. lbs (5.6 - 6.8 Nm).

(62) Fluid cap nuts 50 - 60 in. lbs (5.6 - 6.8 Nm), / alternately and evenly, then re-torque after initial run-in.

LUBRICATION / SEALANTS

○ Apply pipe sealant to threads.

Apply Key-Lube to all "O" rings, "U" cups and mating parts.

Figure 3

PARTS LIST / 81883X FLUID SECTION

★ 862040 Diaphragm Repair Kits include: (standard for models 818833, 818836)	Item #	2	7	8	19	20	33		Grease Packet	Operator's Manual	
	Qty	1	2	2	4	2	4		1	1	
● 862041 Diaphragm Repair Kits include: (standard for models 818831)	Item #	2	3	7	19	20	33	64	Grease Packet	Operator's Manual	
	Qty	1	2	2	4	2	4	2	1	1	
⦿ 862042 Diaphragm Repair Kits include: (standard for models 818832, 818835)	Item #	2	7	19	20	33				Grease Packet	Operator's Manual
	Qty	1	2	4	2	4				1	1
□ 862045 Ball and Seat Repair Kits include: (stainless steel ball and seat) (standard for models 818831, 818833 and 818836, optional for all others)	Item #	19	20	21	22				Grease Packet	Operator's Manual	
	Qty	4	2	4	4				1	1	
◆ 862046 Ball and Seat Repair Kits include: (Teflon ball & stainless steel seat) (optional for all models)	Item #	19	20	21	22				Grease Packet	Operator's Manual	
	Qty	4	2	4	4				1	1	
▲ 862047 Ball and Seat Repair Kits include: (optional Santoprene ball & stainless steel seat) (standard for models 818832 and 818835, optional for all others)	Item #	19	20	21	22				Grease Packet	Operator's Manual	
	Qty	4	2	4	4				1	1	

WETTED COMMON PARTS / 818831, 818832, 818833, 818835, 818836

Item	Description (size in inches)	Qty	818831		818832		818833		818835		818836	
			Part No.	[Mtl]	Part No.	[Mtl]	Part No.	[Mtl]	Part No.	[Mtl]	Part No.	[Mtl]
1	Connecting Rod	(1)	873035	[SS]	873035	[SS]	873035	[SS]	873035	[SS]	873035	[SS]
⦿ ★ ● 2	"O" Ring (3/32" x 5/8" o.d.)	(1)		[B]		[B]		[B]		[B]		[B]
● 3	"O" Ring (1/16" x 9/16" o.d.)	(2)		[T]	-----	---	-----	---	-----	---	-----	---
5	Diaphragm Washer	(2)	873403	[GFN]	873403	[GFN]	873403	[GFN]	873403	[GFN]	873403	[GFN]
6	Diaphragm Nut (5/16" - 18)	(2)	873289	[D]	873290	[P]	873290	[P]	873290	[P]	873289	[D]
⦿ ★ ● 7	Diaphragm	(2)		[T]		[SP]		[T]		[SP]		[T]
★ 8	Diaphragm (models 818833, 818836)	(2)	----	---	-----	---		[SP]	-----	---		[SP]
15	Fluid Cap (Includes items 26 & 124)	(2)	873291	[GA]	873292	[P]	873292	[P]	873292	[P]	873291	[GA]
▲ ⦿ ★ ● 19	"O" Ring (3/32" x 5/16" o.d.)	(4)		[T]		[E]		[T]		[E]		[T]
▲ ⦿ ★ ● 20	"O" Ring (3/32" x 1-1/8" o.d.)	(2)		[T]		[E]		[T]		[E]		[T]
▲ ◆ □ 21	Seat	(4)		[SS]		[SS]		[SS]		[SS]		[SS]
□ 22	Ball (3/4" diameter)	(4)		[SS]		[SS]		[SS]		[SS]		[SS]
◆	Ball (3/4" diameter)	(4)		[T]		[T]		[T]		[T]		[T]
▲	Ball (3/4" diameter)	(4)		[SP]		[SP]		[SP]		[SP]		[SP]
26	Bolt (5/16" - 18 x 1-1/2")	(8)		[SS]		[SS]		[SS]		[SS]		[SS]
29	Nut (5/16" - 18)	(2)		[SS]	-----	---	-----	---	-----	---		[SS]
41	Ball Cage	(4)	873295	[D]	873296	[P]	873296	[P]	873296	[P]	873295	[D]
43	Ground Strap	(1)		[SS]	-----	---	-----	---	-----	---		[SS]
57	Ground Kit Assembly (not shown)	(1)	873067		-----	---	-----	---	-----	---	873067	
60	Manifold, Inlet (Bottom)	(1)	873412	[GA]	873234	[P]	873234	[P]	873234	[P]	873412	[GA]
61	Manifold, Outlet (Top)	(1)	873138	[GA]	873235	[P]	873235	[P]	873235	[P]	873138	[GA]
62	Flange Nut (5/16" - 18)	(24)	-----	---		[SS]		[SS]		[SS]	-----	---
	Flange Nut (5/16" - 18)	(22)		[SS]	-----	---	-----	---	-----	---		[SS]
63	Pipe Plug (1/2 - 14 N.P.T. x 9/16")	(6)	873429	[D]	873428	[P]	873428	[P]	873428	[P]	873429	[D]
● 64	"O" Ring (.210" x 4.576" o.d.)	(2)		[U]	-----	---	-----	---	-----	---	-----	---

MATERIAL CODE

[B] = Nitrile	[P] = Polypropylene
[D] = Acetal	[SP] = Santoprene
[E] = E.P.R.	[SS] = Stainless Steel
[GA] = Groundable Acetal	[T] = Teflon
[GFN] = Glass Filled Nylon	[U] = Polyurethane

PARTS LIST / 81883X FLUID SECTION

COLOR CODE		
MATERIAL	DIAPHRAGM COLOR	BALL COLOR
SANTOPRENE	Tan	Tan
TFE (Teflon)	White	White

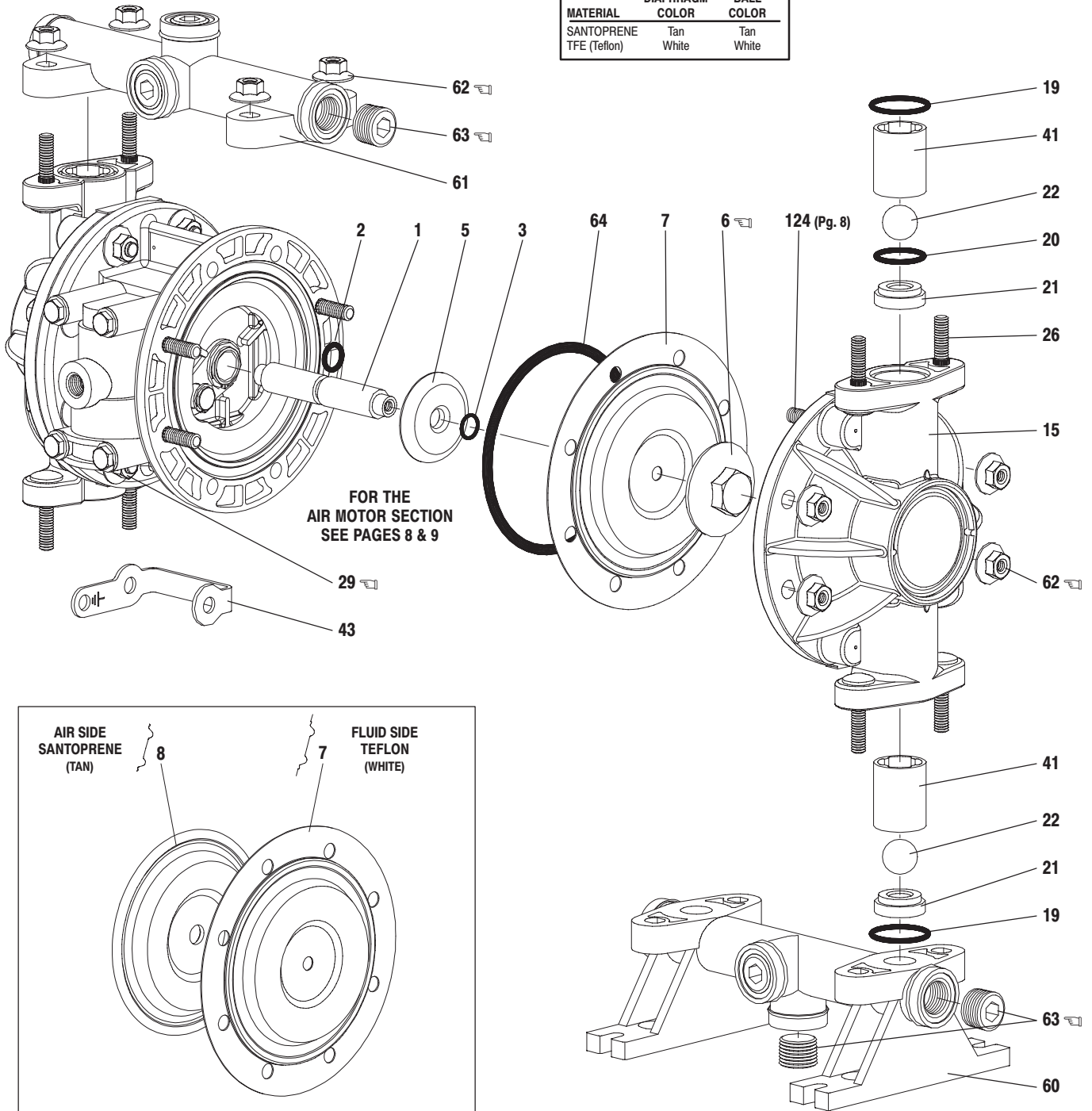

FOR THE AIR MOTOR SECTION SEE PAGES 8 & 9

AIR SIDE SANTOPRENE (TAN) 8

FLUID SIDE TEFLON (WHITE) 7

View of model 818833 and 818836 diaphragm configuration.

TORQUE REQUIREMENTS

NOTE: DO NOT OVERTIGHTEN FASTENERS

- (6) Diaphragm nut 95 - 105 in. lbs (10.7 - 11.9 Nm).
- (29, 62) Fluid caps / Manifold nuts 50 - 60 in. lbs (5.6 - 6.8 Nm), / alternately and evenly, then re-torque after initial run-in.
- (63) Plugs 25 in. lbs (2.8 Nm) maximum.

LUBRICATION / SEALANTS

Apply Keylube to all "O" rings, "U" cups and mating parts.

Figure 4

PARTS LIST / 81883X AIR MOTOR SECTION

(✓) Indicates parts included in 862004 Air Section Repair Kit.

Item	Description (size in inches)	Qty	Part No.	[Mtl]
101	Motor Body	(1)	873297	[P]
✓102	"O" Ring (3/32" x 1" o.d.)	(2)		[B]
103	Sleeve	(1)	873023	[Bz]
104	Snap Ring (13/16")	(2)		[C]
111	Spool	(1)	873298	[D]
118	Pilot Rod (818831, 818834, 818835, 818838)	(1)	873011	[C]
	(818830, 818832, 818833, 818836, 818837)	(1)	873000	[C]
✓119	"O" Ring (1/8" x 3/4" o.d.)	(4)		[B]
120	Spacer	(3)	873280	[Z]
✓122	Snap Ring (1/2")	(2)		[C]
124	Stud (5/16" - 18 x 1-1/2")	(8)		[SS]
	(818831, 818832, 818833, 818835, 818836)			
129	Muffler	(1)	873299	[P]
✓130	Gasket	(1)		[SY]

MATERIAL CODE

[B] = Nitrile	[D] = Acetal	[U] = Polyurethane
[Bz] = Bronze	[P] = Polypropylene	[Z] = Zinc
[C] = Carbon Steel	[SS] = Stainless Steel	
[CK] = Ceramic	[SY] = Syn-Seal	

DIAPHRAGM PUMP SERVICE

GENERAL SERVICE NOTES:

- Inspect and replace old parts with new parts as necessary. Look for deep scratches on metallic surfaces, and nicks or cuts in "O" rings.
 - 7/16" wrench, 1/2" wrench, 7/16" socket, 1/2" socket, torque wrench (measuring inch pounds), "O" ring pick.

FLUID SECTION DISASSEMBLY

- Remove (61) top manifold.
- Remove (19) "O" rings, (21) seats and (22) balls.
- Remove (60 or 35) bottom manifold.
- Remove (19) "O" rings, (21) seats and (22) balls.
- Remove (15) fluid caps.

Item	Description (size in inches)	Qty	Part No.	[Mtl]
131	Bolt (5/16" - 18 x 1-1/4")			
	(models 818830, 818834, 818837, 818838)	(16)		[SS]
	(818831, 818832, 818833, 818835, 818836)	(8)		[SS]
✓132	Gasket	(1)		[B]
133	Washer (9/32" i.d.)	(4)		[SS]
134	Cap Screw (1/4" - 20 x 5")	(4)		[SS]
135	Valve Block	(1)	873300	[P]
136	Plug	(1)	873301	[D]
✓137	"O" Ring (3/32" x 1-1/2" o.d.)	(1)		[B]
✓138	"U" Cup Packing (1/8" x 1" o.d.)	(1)		[U]
✓139	"U" Cup Packing (1/8" x 1-7/16" o.d.)	(1)		[B]
✓140	Valve Insert	(1)	873038	[CK]
✓141	Valve Plate	(1)	873039	[CK]
142	Washer	(2)	873302	[Z]
143	Plate	(2)	873303	[SS]
✓	Keylube, "O" Ring Lubricant	(1)		

- Remove (14) bolt, (6) diaphragm washer, (7 / 8) diaphragms and (5) washer.
- Remove (1) connecting rod from air motor.
- Carefully remove remaining (14) bolt, (6) diaphragm washer, or (7 / 8) diaphragms and (5) washer from (1) connecting rod. Do not mar surface of connecting rod.
- Remove (2) "O" ring from connecting rod.

FLUID SECTION REASSEMBLY

- Reassemble in reverse order.
- Lubricate (1) connecting rod and (2) "O" ring with Key-Lube or equivalent "O" ring lubricant.
- Install (5) washers with i.d. chamfer toward diaphragm.
- When replacing Teflon diaphragms, install the (8) Santoprene diaphragm behind the Teflon diaphragm.
- Before tightening (39) nut on (38) carriage bolts on (36) swivels, attach the manifold / swivel assembly to the (15) fluid caps. Rotate the (36) swivel to the desired position and tighten each of the (39) nuts approximately 8 - 9 turns, then finish tightening the (39) nuts.

PARTS LIST / 81883X AIR MOTOR SECTION

TORQUE REQUIREMENTS
NOTE: DO NOT OVERTIGHTEN FASTENERS.
 (134) Torque to 15 - 20 in. lbs (1.7 - 2.3 Nm), wait 10 minutes, then re-torque to 15 - 20 in. lbs (1.7 - 2.3 Nm).

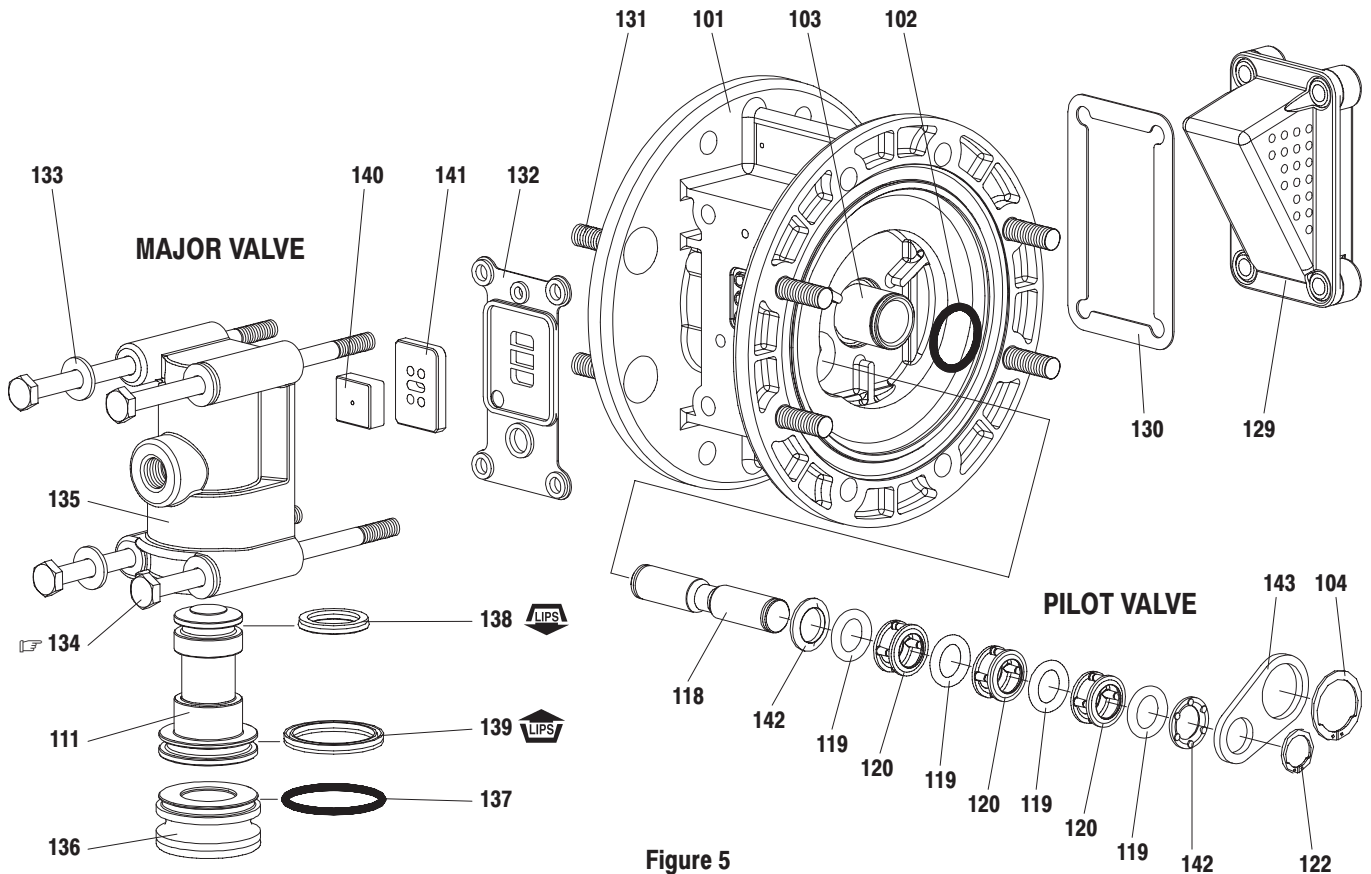

Figure 5

AIR MOTOR SECTION SERVICE

Service is divided into two parts - 1. Pilot Valve, 2. Major Valve.
 • Air Motor Section Service is continued from Fluid Section repair.

PILOT VALVE DISASSEMBLY

1. Remove (122 and 104) snap rings.
2. Remove (143) plates.
3. Remove (103) sleeve and (102) "O" rings.
4. Remove (118) pilot rod, (142) washers, (119) "O" rings and (120) spacers from (101) center body.

PILOT VALVE REASSEMBLY

1. Assemble (119) "O" rings, (120) spacers and (142) washers on (118) pilot rod.
2. Insert the stack into the (101) body. Sleeve (103) may be used to assist pressing stack into body.
3. Install (103) sleeve and (102) "O" rings into (101) body.
4. Install (143) plates and (122 and 104) snap rings.

MAJOR VALVE DISASSEMBLY

1. Remove (129) muffer and (130) gasket.
2. Pull (135) valve block assembly from (101) motor body.
3. Remove (134) bolts, (133) washers and (132) gasket from (135) valve block.
4. Remove (141) valve plate and (140) valve insert.
5. Remove (136) plug and (111) spool.

MAJOR VALVE REASSEMBLY

1. Install new (139 and 138) "U" cups on (111) spool - **LIPS MUST FACE EACH OTHER.**
2. Insert (111) spool into (135) valve block.
3. Install (137) "O" ring on (136) plug, insert plug into (135) valve block.
4. Install (140) valve insert and (141) valve plate into (135) valve block. Note: Assemble (140) valve insert with "dished" side toward (141) valve plate. Assemble (141) valve plate with 2 identification dots toward (132) gasket.
5. Replace (132) gasket and install valve block assembly on (101) body.

TROUBLE SHOOTING

Product discharged from air exhaust.

- Check for diaphragm rupture.
- Check tightness of (6) diaphragm nut or (14) bolt.

Air Bubbles in product discharge.

- Check connections of suction plumbing.
- Check band clamps on intake manifold (non-metallic models).
- Check "O" rings between intake manifold and fluid caps.
- Check tightness of (6) diaphragm nut or (14) bolt.

Pump blows air out main exhaust when stalled on either stroke.

- Check "U" cups on (111) spool in major valve.
- Check (141) valve plate and (140) insert for wear.
- Check (103) sleeve and (2) "O" ring on diaphragm connecting rod.
- Check (119) "O" rings on (118) pilot rod for wear.

Low output volume.

- Check air supply.
- Check for plugged outlet hose.
- For the pump to prime itself, it must be mounted in the vertical position so that the balls will check by gravity.
- Check for pump cavitation - suction pipe should be 1/2" minimum or larger if high viscosity fluids are being pumped. Suction hose must be non-collapsible type, capable of pulling a high vacuum.
- Check all joints on intake manifolds and suction connections. These must be airtight.
- Check for sticking or improperly seating check valves.
- If pump cycles at a high rate or runs erratically, check (119) piston "O" rings for wear.

DIMENSIONAL DATA / 818830, 818834, 818837, 818838

Dimensions shown are for reference only, they are shown in inches and millimeters (mm).

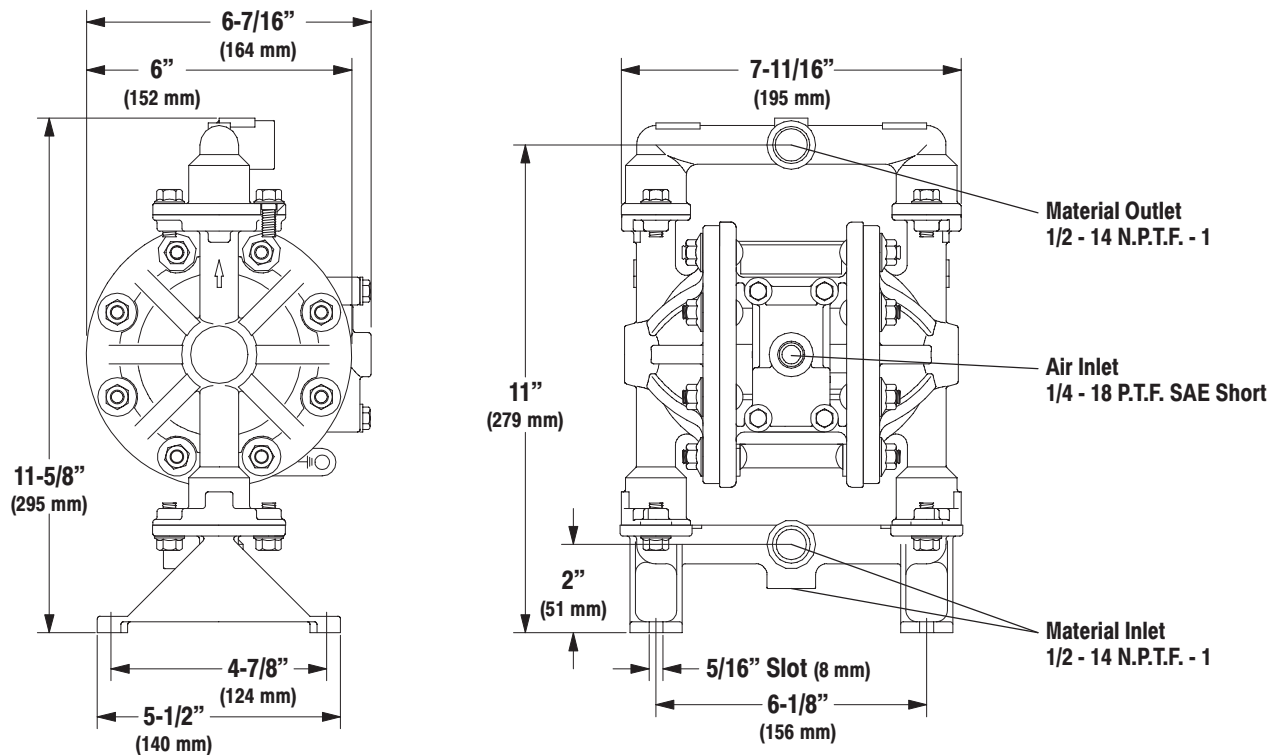

Figure 6

DIMENSIONAL DATA / 818831, 818832, 818833, 818835, 818836

Dimensions shown are for reference only, they are shown in inches and millimeters (mm).

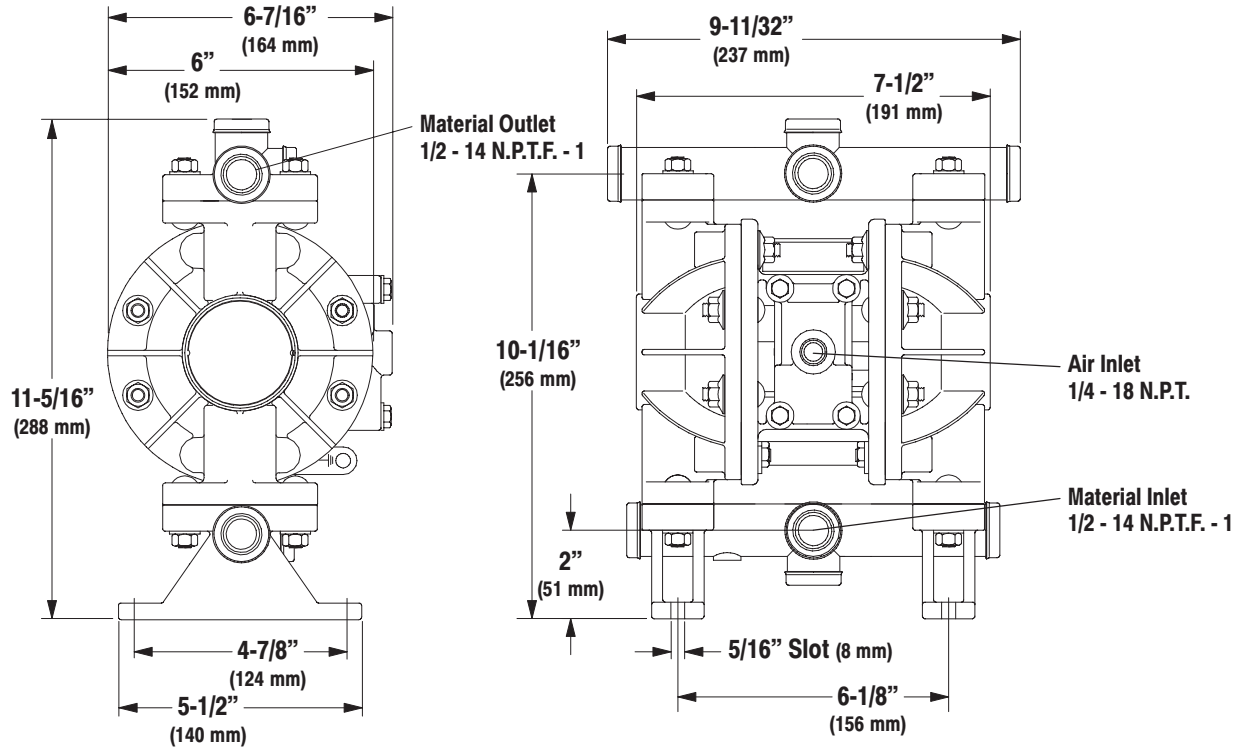
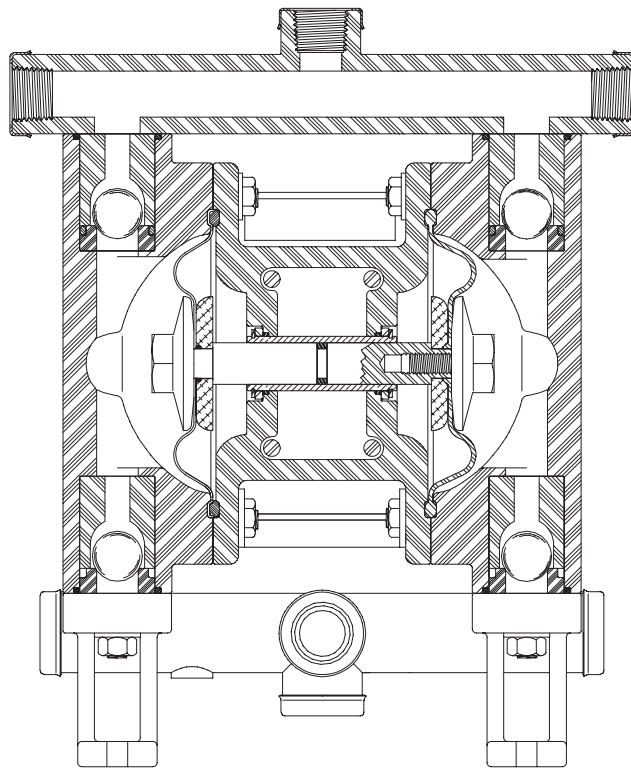
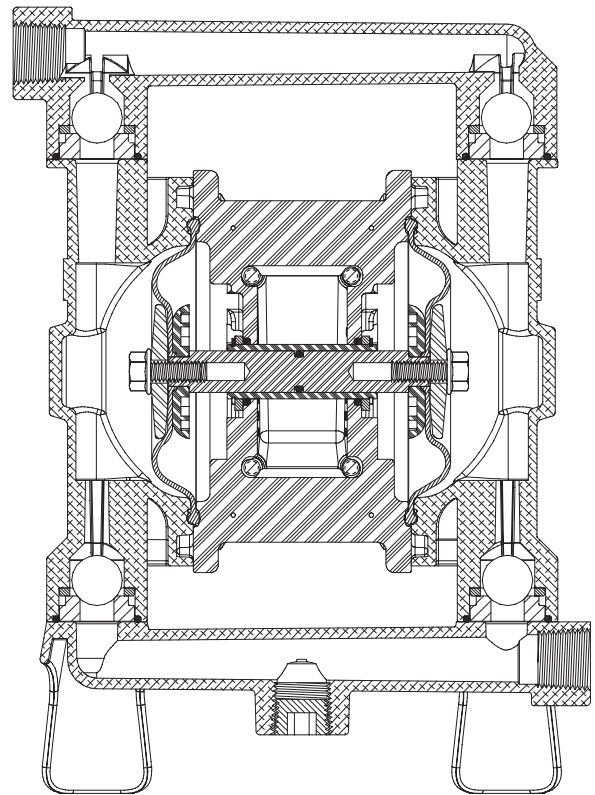

Figure 7

CROSS SECTION



818831, 818832, 818833, 818835, 818836



818837, 818838

Figure 8

