



Binks Cub SL HVLP TOUCH-UP and COATINGS SPRAY GUN

7011-XXXX-X

Binks Mach 1 Cub SL HVLP Gun is the finest touch-up and specialty coatings gun available today. The gun has been ergonomically designed to give operators superb control and comfort over a range of uses. You feel the gun's excellent balance and heft as soon as you pick it up. The Mach 1 Cub SL offers three options for fluid supply: siphon feed, pressure assist feed, and pressure feed tank hook-ups, making it one of the most flexible guns for touch-up work available. The gun body is made of the finest forged aluminum and machined to exacting tolerances. Overall quality is reflected in the gun's lustrous and durable anodized finish.

The Mach 1 Cub SL gun operates at high efficiencies, transferring 65 percent or more of the fluid to the substrate.

It fully meets operating pressures and material transfer requirements of California's South Coast Air Quality Management District regulations as a high volume, low pressure spray gun. High pressure, low volume air flow is converted to high volume, low pressure flows within the gun body. Special air and fluid nozzles enable the gun to atomize fluid at low velocities, creating a soft spray effect for high transfer efficiencies.

The Mach 1 Cub SL gun is especially favored in the automotive touch-up and detailing industries and is well-suited to other specialty finishing and small area applications. Several options in fluid nozzle sizes make the gun adaptable to a variety of uses. See the Parts List on page 2 and Fluid Nozzle Table on page 7 for these options.

This Part Sheet contains an exploded drawing and detailed parts list to enable a complete understanding of the gun's construction. A basic overview of gun operation, cleaning, care and maintenance, and troubleshooting of common problems is also provided.

NOTE

IMPORTANT REGULATORY NOTE regarding the use of this product appears on page 6.

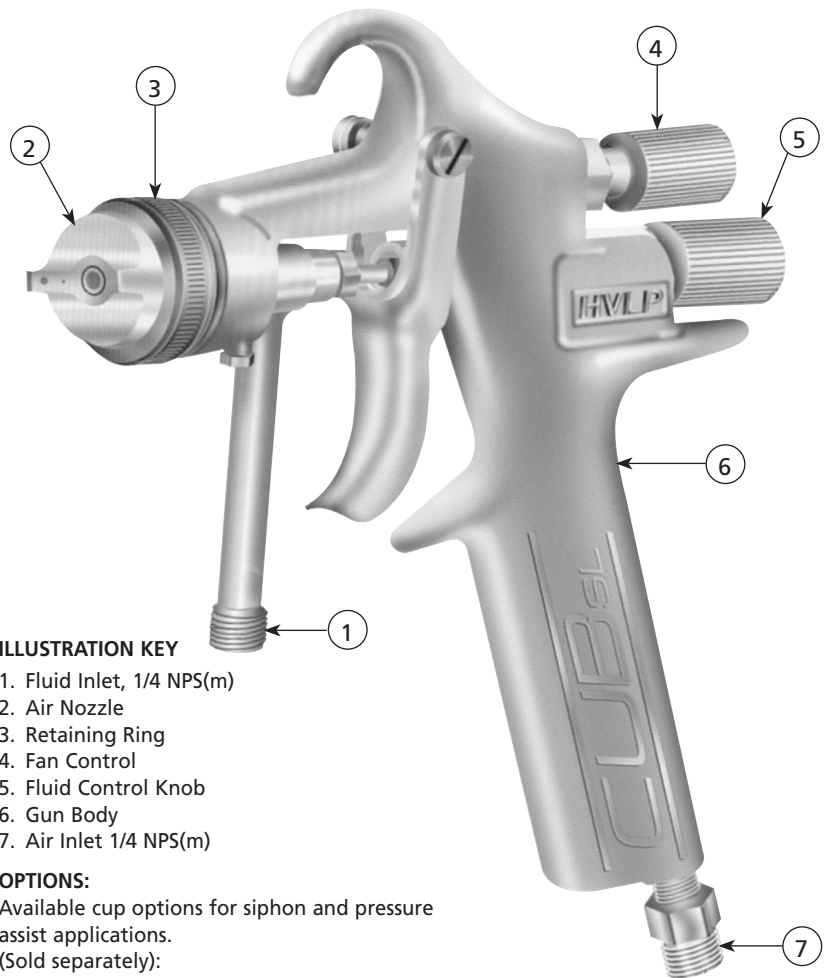

ILLUSTRATION KEY

- 1. Fluid Inlet, 1/4 NPS(m)
- 2. Air Nozzle
- 3. Retaining Ring
- 4. Fan Control
- 5. Fluid Control Knob
- 6. Gun Body
- 7. Air Inlet 1/4 NPS(m)

OPTIONS:

Available cup options for siphon and pressure assist applications.

(Sold separately):

- 8 Ounce Siphon Cup Assembly 81-384
- 8 Ounce Pressure Assist Cup Assembly 81-382

The Mach 1 Cub SL can also be used with pressure-feed tank hook-ups. More information about these uses can be found on page 3.

PACKAGE CONTENTS

Please note your Binks Mach 1 Cub SL Gun Package was shipped with the following contents. If anything in the following list is missing, contact 1-800-992-4657.

DESCRIPTION	PART NO.	QTY.
Mach 1 Cub SL HVLP Spray Gun		1
Gunners Mate.....	54-3871	1
Cub SL Part Sheet.....	77-2734	1
Small Brush.....	54-4133	1
Gun Brush.....	OMX-88	1
Product Registration Card.....	77-5177	1

Binks Cub SL HVLP SPRAY GUN

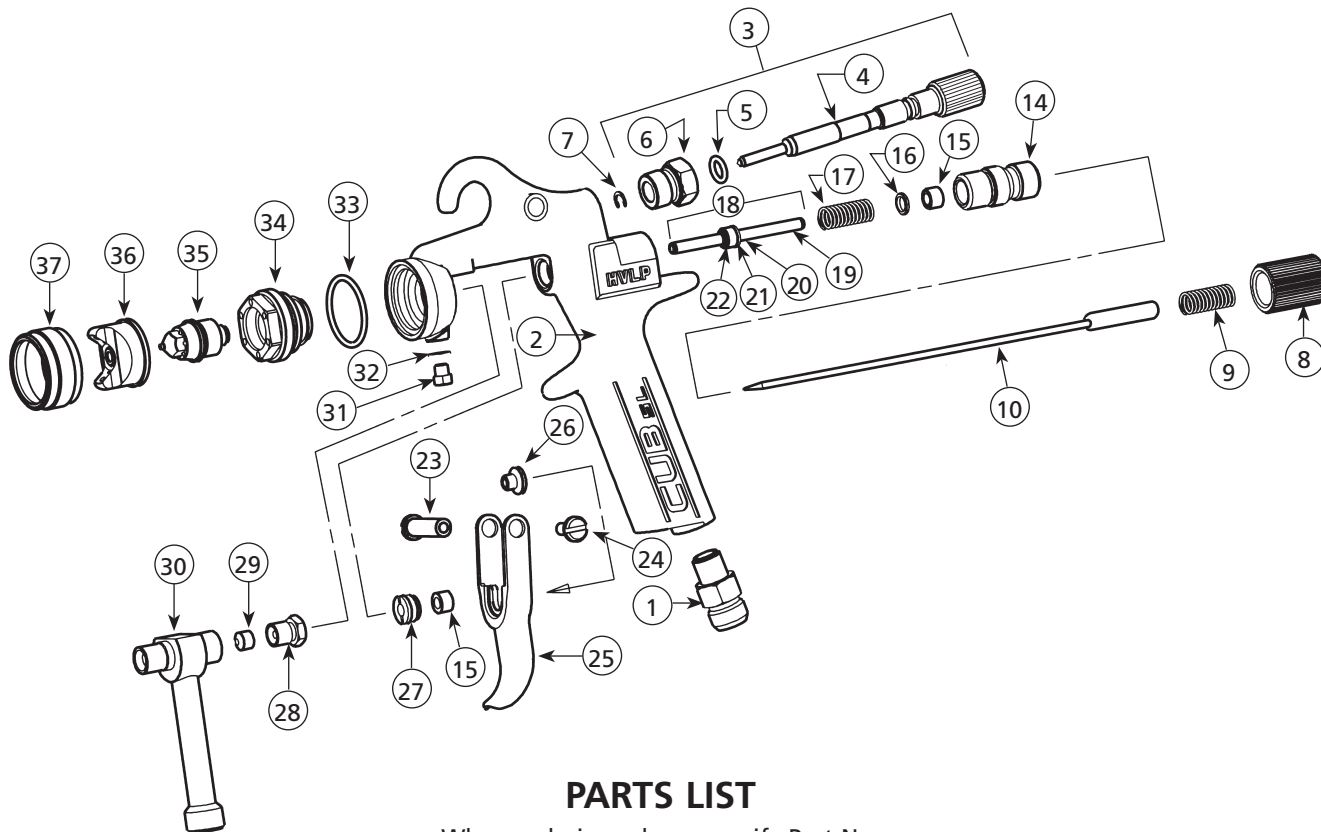

PARTS LIST

When ordering, please specify Part No.

ITEM NO.	PART NO.	DESCRIPTION	QTY.	ITEM NO.	PART NO.	DESCRIPTION	QTY.
1	71-28†	D. M. NIPPLE 1/8 NPT(m) x 1/4 NPS(m)	1	19	■	SPINDLE	1
2	54-4491†	HANDLE ASSEMBLY	1	20	■	RETAINING RING	1
3	54-4115	FAN CONTROL ASSEMBLY	1	21	■	WASHER	1
4	■	FAN CONTROL KNOB	1	22	■	AIR VALVE SEAL	1
5	■▲	O-RING PTFE, Split	1	23	54-4482	TRIGGER STUD	1
6	▲	FAN CONTROL HOUSING	1	24	54-4483	TRIGGER SCREW	1
7	■▲	RETAINING RING	1	25	54-4462	TRIGGER	1
8	54-4128	FLUID CONTROL KNOB	1	26	54-4125▲	SPINDLE CAP	1
9	54-4495▲	SPRING Stainless Steel	1	27	54-4134▲	SEAL RETAINER	1
10	54-4493	FLUID NEEDLE	1	28	55-847▲	PACKING NUT	1
11	OMX-88	FAN BRUSH (Page 4)	1	29	55-846▲	PACKING	1
12	54-4133	GUN BRUSH (Page 4)	1	30	54-4107	FLUID INLET 1/4" NPS (m)	1
13	54-4130 ○	WRENCH (Page 4) (Optional)	1	31	54-3928†	PLUG 10-32 x 1/4 Hex Head	1
14	54-4127†	REAR HOUSING	1	32	54-3925	GASKET	1
15	54-4131▲	U-CUP SEAL	2	33	20-5740▲	O-RING 2-020 PTFE	1
16	54-4126▲	WASHER	1	34	54-4124†	HEAD INSERT	1
17	54-3520▲	YELLOW SPRING	1	35	**†	FLUID NOZZLE	1
18	54-4119▲	AIR VALVE ASSEMBLY	1	36	**■	AIR NOZZLE	1
				37	54-4123	RETAINING RING	1

- Available as part of its assembly.
- ▲ Included in Spare Parts Kit 54-4478.
- ** Choose from chart on page 7.
- † Torquing information. (See chart at right).
- See note in chart on page 7.
- Not furnished; please order separately.

TORQUING INFORMATION

Item	Description	Torque Spec.
1	D.M. Nipple	48"/lbs.
3	Fan Control Assembly	48"/lbs.
14	Rear Housing	72"/lbs.
31	Plug, 10-32 x 1/4 Hex Head	10"/lbs.
34	Head Insert	144"/lbs.
35	Fluid Nozzle	84"/lbs.

1. Lubricate all threads and o-rings before assembly.
2. Apply Loctite PST thread sealant to rear housing, fan control assembly, and seal retainer before assembly.

NOTE

To ensure the best possible performance and longevity of your gun, do not over-tighten its components. Check the chart at right to see the appropriate amount of torque for your gun.

HOW TO SET UP and OPERATE YOUR Binks Cub SL HVLP SPRAY GUN

Your new Binks Mach 1 Cub SL HVLP gun is exceptionally rugged in construction and is built to stand up under hard, continuous use. However, like any other precision instrument, its most efficient operation depends on a knowledge of its construction, operation and maintenance. Properly handled and cared for, it will produce beautiful, uniform finishes long after other spray guns are worn out.

The Mach 1 Cub SL gun can be used in three modes: siphon feed, pressure assist, or pressure feed tank hook-ups. In siphon mode, lowered air pressure in the gun draws fluid from the cup into the gun. The pressure assist function works when air flows through the cup's check valve assembly, pressurizing the liquid in the cup and forcing it up into the gun. Pressure feed modes for tanks rely on systems that separately regulate fluid and air flow. Instructions for assembling the gun with either the siphon cup or pressure assist cup are included here and also with the cup assemblies. Below are brief descriptions and illustrations of the siphon feed, the pressure assist, and the pressure feed tank hook-ups.

CA PROP
65

PROP 65 WARNING
WARNING: This product contains chemicals known to the State of California to cause cancer and birth defects or other reproductive harm.

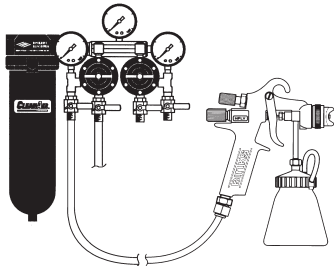

SIPHON FEED CUP HOOK-UP

Air pressure for atomization is regulated at extractor. The amount of fluid is adjusted by fluid control knob on gun, viscosity of paint, and air pressure.

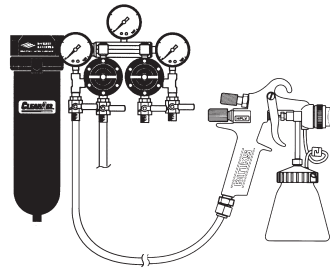

PRESSURE ASSIST CUP HOOK-UP

Air pressure for atomization is regulated at the extractor. The fluid pressure is from the front of the gun, through check valve to cup.

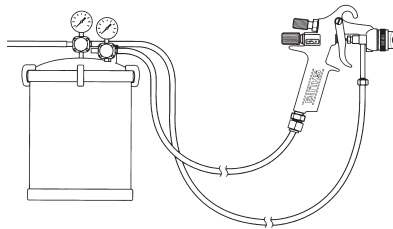

PRESSURE FEED TANK HOOK-UPS

For portable painting operations, use a double regulator pressure feed tank hook-up. Air pressure for atomization and for fluid supply is regulated by two separate air regulators on tank. The Mach 1 Cub SL comes standard with a 40T fluid nozzle to be used in siphon feed operations, see note on page 7 regarding nozzle options and materials use.

HOW TO SET UP YOUR GUN FOR SIPHON APPLICATIONS (See Cup Part Sheet for Parts Identification)

1. Attach one end of vent tube to connector on cup lid.
2. Push the other end of vent tube down through loop on side of cup lip.
3. Insert the threaded fluid inlet into the swivel nut, taking care to position the vent tube away from the gun trigger.
4. Rotate the swivel nut until tight to attach the cup to the fluid inlet.

HOW TO SET UP YOUR GUN FOR PRESSURE ASSIST OPERATIONS

1. Screw the swivel nut onto the threaded end of the fluid inlet.
2. Remove the 1/4" plug and gasket from the gun.
3. Replace the plug and gasket with the connector supplied with the cup assembly.

CAUTION

Over-tightening connector will damage its delicate threading.

4. Slip the longer end of the check valve assembly over the gun connector and attach the shorter end to the connector on the cup lid.

WARNING

REGARDING AIR PRESSURE SAFETY
Shut off air pressure before connecting or disconnecting air hose or removing any components from the gun. Air should be supplied by a suitable length of 1/4" diameter air hose fitted with a 1/4" NPS(f) connector at the gun end. For hose lengths over 25', use 5/16" diameter hose.

CONNECTING TO AIR HOSE

WARNING

REGARDING PAINTS, SOLVENTS AND OTHER COATINGS SAFETY
Do not use open containers for storage or disposal of paint, other coatings, cloth, or paper used in preparation and application. Many paints and coatings contain volatile chemicals that are a cause of pollution and are a health and fire hazard. Always wear appropriate clothing, including gloves, and eye protection, and a respirator when using the gun.

CONTROLLING FLUID FLOW

Air pressure for atomization is regulated at the extractor (see illustration pg. 4). The flow of fluid is adjusted by the fluid control knob on the gun, and by paint viscosity, air pressure, and nozzle size. Nozzles with larger apertures give higher flow rates. You can adjust fluid flow by turning the fluid control knob. Turn clockwise to restrict the needle opening, counterclockwise to enlarge it.

HOW TO CLEAN and MAINTAIN YOUR Binks Cub SL HVLP SPRAY GUN

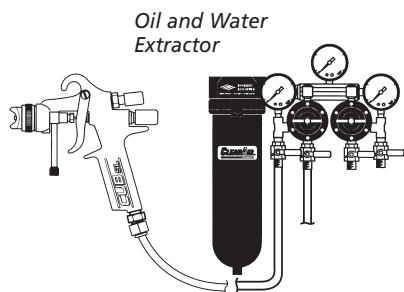

DEVILBISS CLEAN AIR SEPARATOR FILTER

Achieving a fine spray finish without the use of a good oil and water extractor is almost impossible. A DeVilbiss regulator/separator serves a double purpose. It eliminates blistering and spotting by keeping air free of oil and water, and it gives precise air pressure control.

We recommend the DeVilbiss HFRL-509 regulator/separator for use with the Mach 1 Cub SL gun.

CONTROLLING FAN SPRAY

Fan spray is controlled by the fan control knob. Turning this knob clockwise until it is closed will give a small, circular spray pattern. Opening it counterclockwise widens the pattern to a fan shape. You can adjust the fan pattern to any angle by changing the position of the air nozzle by loosening the retaining ring, rotating the air nozzle to the desired position, and re-tightening the retaining ring.

See **WARNING Regarding Solvent Safety, Page 3.**

CLEANING YOUR GUN

1. Shut off air supply and relieve pressure in the gun by triggering it.
2. Remove the siphon or pressure assist cup, empty it, and rinse it

CAUTION

Do not allow the cup to remain in contact with solvent for extended periods of time. Prolonged exposure to solvent may damage the cup.

out with solvent.

3. Turn the gun over and pour solvent into the fluid inlet (30).
4. Trigger the gun to allow solvent to flow through the gun.

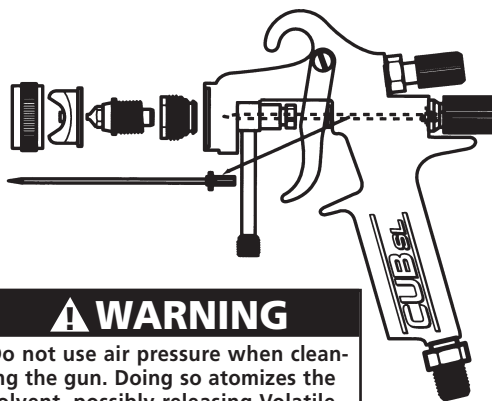

WARNING

Do not use air pressure when cleaning the gun. Doing so atomizes the solvent, possibly releasing Volatile Organic Compounds (VOCs) into the air, which may violate local air quality regulations and may also pose a health risk.

5. Use the gun brush (12) to clean the fluid inlet and the fluid nozzle (35).

CAUTION

Never use anything metal to clean the air nozzle or fluid nozzle. These parts are precisely machined, and any damage to them will cause faulty spray patterns.

6. Use the fan brush (11) to clean the outside of the gun.
7. Repeat any step above until the gun is clean.
8. Blow air through the gun until dry.
9. **OPTION:** Disconnect the gun from the air hose and remove the air and fluid nozzles if they need separate cleaning. Remove the fluid needle (10) and wipe it clean.
10. **OPTION:** If the gun has been used in pressure assist mode, replace the gasket (32) and plug (31) or place your finger over the opening to prevent solvent from leaking out as you rinse the gun's interior.

CLEANING YOUR SIPHON AND PRESSURE ASSIST CUPS

1. Remove the vent tube or check valve assembly from the gun and cup assembly.
2. Unscrew the cup from the gun and rinse cup in solvent.

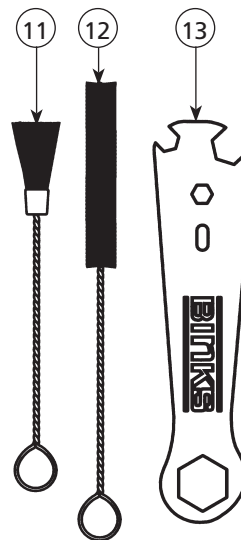

3. Using a cloth soaked in solvent, wipe the vent tube or check valve assembly to remove paint.

CAUTION

Never soak vent tube or check valve assembly in solvent. Doing so may cause the Viton o-ring to swell and not function properly.

CLEANING GUN USED WITH PRESSURE CONTAINERS

1. Shut off air supply to container and release pressure on the container.
2. Hold a piece of cloth wadded in your hand over the gun nozzle and pull the trigger. Air will back up through the fluid nozzle and force material out of the hose into the container.
3. Empty container. Add enough thinner to the container to wash the hose and gun thoroughly.
4. Spray the solvent through the gun until it's clean.
5. Blow out the material hose to dry it and remove all traces of material by attaching it to the air line.

CLEANING YOUR GUN UNDER PRESSURE

It has been customary in the industry to clean paint guns by spraying solvent through them under air pressure. This method is less effective than the steps described above. In addition, it may violate local air quality regulations. Spraying solvent under pressure atomizes it and may release Volatile Organic Compounds (VOCs) into the air.

HOW TO CLEAN and MAINTAIN YOUR Binks Cub SL HVLP SPRAY GUN

If you wish to clean the gun using this method, we recommend one of the following alternatives:

1. Spray solvent through the gun into a closed system. An enclosed unit or spray gun cleaning station condenses solvent vapors and captures them, preventing the escape of VOCs into the atmosphere.
2. Place the spray gun in a washer type cleaner. This system must totally enclose the gun, cup, nozzles and other parts during washing, rinsing and draining cycles. This type of unit must be able to flush solvent through the gun without releasing VOCs vapors.
3. When using a washer to clean cups, take care not to immerse either siphon or pressure assist cups in solvent for long periods of time. Doing so will weaken the cups.

HOW TO MAINTAIN YOUR GUN

All part names and item numbers in parentheses refer to the exploded drawing and Parts List on page 2.

TO REPLACE THE AIR VALVE ASSEMBLY (18) OR THE REAR U-CUP SEAL (15)

1. Remove the fluid control knob (8), stainless steel spring (9) and needle assembly (10).
2. Unscrew the rear housing (14) using a 5/16" hex wrench. Inside the rear housing is the washer (16) and the rear u-cup seal.
3. Remove the washer. The rear u-cup seal can be pushed out from behind if you need to replace it.
4. Remove the yellow spring (17).
5. Holding the spindle cap (26) to avoid losing it, pull out the air valve assembly.
6. Replace and reassemble in reverse order.
 - Lightly lubricate new seals with petroleum jelly.

- Note the orientation of the rear u-cup seal: the open side should face the front of the gun.
- Take care when starting the rear housing into the gun. Make sure the air valve assembly is lined up with the rear u-cup seal; otherwise, the end of the air valve spindle (19) may damage the seal.

TO REPLACE THE FRONT U-CUP SEAL (15)

1. Remove the air valve assembly as described on the previous page.
2. Remove the retaining ring (37), fluid inlet (30) air nozzle (36), fluid nozzle (35), head insert (34), o-ring (33) from the front of gun.
3. Unscrew the trigger screw (24) from the trigger stud (23) and remove the trigger stud and trigger from the handle assembly (2). Note the direction in which the spindle cap (26) is positioned.
4. Use a screwdriver to unscrew the seal retainer (27).
5. Push out the front u-cup seal and replace it.
6. Reassemble in reverse order.
 - Lightly lubricate new seals with Gunner's Mate.
 - Note the orientation of the front u-cup seal: the open side should face the back of the gun.

TO REPLACE THE PACKING (29) IN THE FLUID INLET (31)

1. Remove the fluid control knob (8), stainless steel spring (9), and needle assembly (10).
2. Unscrew the packing nut (28).
3. Remove the packing using a stiff wire hook or small sheet metal screw.
4. Replace the packing and reassemble in reverse order.

TO REPLACE THE O-RING (5) IN THE FAN CONTROL ASSEMBLY (3)

1. Remove the fan control assembly.
2. Pry off the retaining ring (7).
3. Unscrew the fan control housing (6).
4. Remove and replace the o-ring.
5. Reassemble.

GENERAL INSTRUCTIONS FOR AIR SUPPLIED PAINT SPRAYING

To reduce overspray and obtain maximum efficiency, always spray with the lowest possible fluid and air pressure that produces an acceptable spray pattern. Excessive atomizing air pressure can increase overspray, reduce transfer efficiency, and with some materials, result in poor finish quality from dry spray. Atomizing air pressures should not exceed 10 psi. See the tables on page 6 and Important Regulatory Note on page 8.

For best results with pressure feed set-ups use 1 to 4 psi fluid pressure. Higher than 4 psi fluid pressure may be required for heavy-bodied materials. Low fluid pressure will produce a narrower than normal spray pattern.

Generally use 30-35 psi air at the gun inlet (see page 7). Unusually heavy, difficult to atomize materials may require up to 50 psi air at the gun inlet.

NOTE

Take care not to lose the spindle cap (26).

SPRAY TECHNIQUE FOR YOUR Binks Cub SL HVLP SPRAY GUN

SPRAY TECHNIQUE

To get a good finish you must handle the gun properly. Hold the gun perpendicular to the surface you are

WARNING

Always wear appropriate gloves, eye protection and a respirator when using your gun.

painting. Make each paint stroke parallel to the plane of the surface being painted. Start the stroke before you trigger the gun and release the trigger before you end the stroke. This will give you accurate control of both gun and material and prevent excessive build-up of material at the stroke ends.

The distance between the gun and surface should be 6"-10" depending on the material and the atomizing pressure. The material deposited should always be even and wet. Lap each stroke about half of the preceding stroke to obtain a uniform finish.

IF YOU HAVE TROUBLE WITH GUN OPERATION OR RESULTING FINISH

FAULTY SPRAY PATTERN

A faulty spray pattern is often caused by dried materials around the fluid nozzle tip or in the air nozzle left behind by improper cleaning. Soak these parts in thinner to soften the material and remove it with brush or cloth.

INTERMITTENT SPRAY

Fluttering spray is caused by one of the following problems:

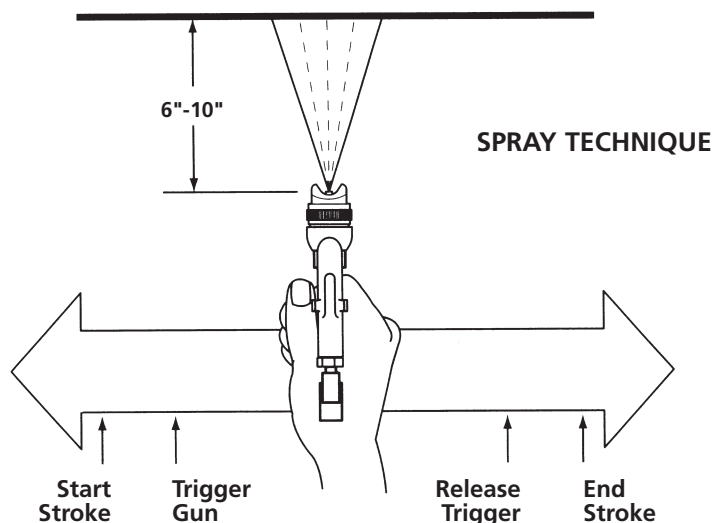

CAUTION

Never use anything metal to clean the air nozzle. These parts are precisely machined, and any damage to them will cause faulty spray patterns.

1. The nut that attaches the fluid cup may be loose. The packing nut (28) may be loose. The packing (29) may be worn and need replacement. The fluid nozzle (35) may be loose.
2. Insufficient fluid available. Refill the cup.

SPITTING

Spitting is caused by anything that restricts the movement of the fluid needle assembly (10). The probable causes are:

1. The packing nut (28) is too tight.
2. The fluid needle (13) is bent. You may be able to straighten it. Otherwise, it must be replaced.
3. Dried material has built up on the needle or in the fluid nozzle (35).
4. Lumps or impurities in the fluid. Strain the fluid.

IMPORTANT REGULATORY NOTE

Regulations in some areas prohibit the operation of HVLP spray guns above 10 psi nozzle atomizing pressure. users subject to this regulation should not exceed 50 psi gun inlet pressure (see the air pressure chart for various fluid materials on page 7). Some agencies require users to have a nozzle test gauge available on site to verify gun operating pressures. We recommend that you use Nozzle Test Gauge (Part No. 54-4150) shown below for accurate nozzle operating pressures.

FLUID NOZZLE OPTIONS, AIR PRESSURE RECOMMENDATIONS

FLUID NOZZLE OPTIONS

Material

Very Light/Reduced Flow

Fluid Nozzle No.

20T (.020" dia. opening)

Light/Medium: less than 15 to 20 seconds in a ZAHN 2 Cup,
e.g., stains, varnishes, thin lacquers, automotive refinishing materials

40T (.040" dia. opening)

Medium: 20 to 30 seconds in a ZAHN 2 Cup,
e.g., general industrial coatings

55T (.055" dia. opening)

Heavy: greater than 30 seconds in a ZAHN 2 Cup,
e.g., low VOCs coatings

55T (.055" dia. opening)

■ All fluid nozzles use the **2S air nozzle**.

■ The **2S air nozzle** is recommended for siphon applications or pressure-assist applications.

For Binks Cub SL Spray Guns using pressure or pressure-assist, use nozzle 20T for light/medium materials and 40T for heavier materials. Use of larger nozzles or of very light materials with a pressurized gun will result in excessive material flows and is not recommended.

AIR PRESSURES AND FLOWS

Gun Inlet Pressure (PSI)	Nozzle Atomizing Air Flow (SCFM)	Nozzle Atomizing Pressure (PSI)
20	6.0	3
30	7.5	5
45	10.0	9
50	11.0	10

Gun inlet pressure is measured at the gun inlet fitting with the gun triggered.

AIR PRESSURE RECOMMENDATIONS

Type of Material	Atomizing PSI	Gun Inlet PSI	Regulator PSI
Primer/Surfaces	3-4	20-26	27-33
Light Stains/Inks	4-5	26-30	33-38
Acrylic Enamels	6-7	35-40	44-47
Lacquers	7-8	40-42	47-55
Low VOCs, Urethanes	8-10	42-50	55-59

Regulator pressures are based on 25' of 1/4" hose in good condition without quick disconnects or other restrictive fittings. Gun inlet pressures are measured at the gun air inlet with the gun triggered. Use the Air Nozzle Test Gauge Accessory 54-4150 to confirm the atomizing/regulator pressure for your actual air supply set-up. These recommendations are typical for average fluids, and are intended to serve as a starting point. Adjust as necessary for your specific application. Regulator pressures for 5/16" hose are 3 to 5 PSI lower.

ACCESSORIES

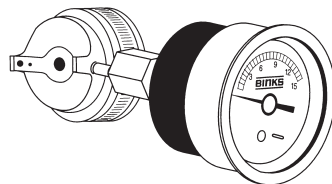

**TEST GAUGE ACCESSORY
54-4150
(GAUGE ONLY: 59-299)**

WARRANTY POLICY

Binks products are covered by Finishing Brands one year materials and workmanship limited warranty. The use of any parts or accessories, from a source other than Finishing Brands, will void all warranties. For specific warranty information please contact the closest Finishing Brands location listed below.

Finishing Brands reserves the right to modify equipment specifications without prior notice. DeVilbiss®, Ransburg®, BGK®, and Binks® are registered trademarks of Carlisle Fluid Technologies, Inc., dba Finishing Brands. ©2015 Carlisle Fluid Technologies, Inc., dba Finishing Brands. All rights reserved.



Binks is part of Finishing Brands, a global leader in innovative spray finishing technologies. For technical assistance or to locate an authorized distributor, contact one of our international sales and customer support locations below.

USA/Canada

www.binks.com
info@carlisleleft.com
Tel: 1-800-992-4657
Fax: 1-888-246-5732

Mexico

www.carlisleleft.com.mx
ventas@carlisleleft.com.mx
Tel: 011 52 55 5321 2300
Fax: 011 52 55 5310 4790

Brazil

www.devilbiss.com.br
vendas@carlisleleft.com.br
Tel: +55 11 5641 2776
Fax: 55 11 5641 1256

United Kingdom

www.finishingbrands.eu
info@carlisleleft.eu
Tel: +44 (0)1202 571 111
Fax: +44 (0)1202 573 488

France

www.finishingbrands.eu
info@carlisleleft.eu
Tel: +33(0)475 75 27 00
Fax: +33(0)475 75 27 59

Germany

www.finishingbrands.eu
info@carlisleleft.eu
Tel: +49 (0) 6074 403 1
Fax: +49 (0) 6074 403 281

China

www.finishingbrands.com.cn
mkt@carlisleleft.com.cn
Tel: +8621-3373 0108
Fax: +8621-3373 0308

Japan

www.ransburg.co.jp
overseas-sales@carlisleleft.co.jp
Tel: 081 45 785 6421
Fax: 081 45 785 6517

Australia

www.finishingbrands.com.au
sales@carlisleleft.com.au
Tel: +61 (0) 2 8525 7555
Fax: +61 (0) 2 8525 7500

