

COLOR VALVE STACK

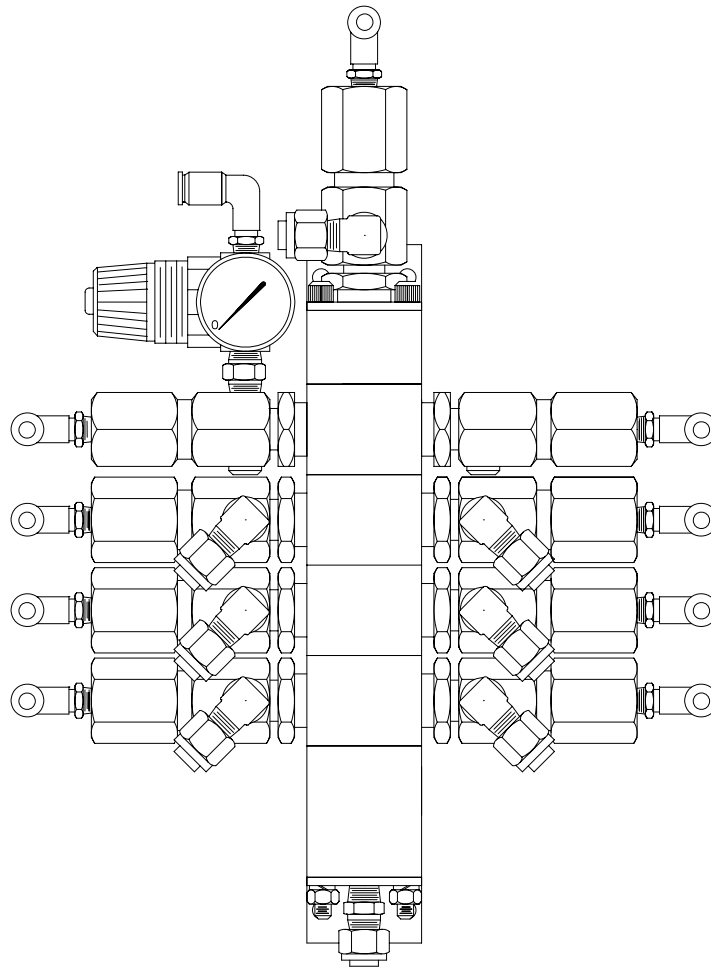

MODEL: CCV-5100



IMPORTANT: Before using this equipment, carefully read **SAFETY PRECAUTIONS**, starting on page 1, and all instructions in this manual. Keep this Service Manual for future reference.

Service Manual Price: €25.00 (Euro)
\$30.00 (U.S.)

NOTE: This manual has been changed from revision LN-9113-06 to revision LN-9113096.1.
Reasons for this change are noted under “Manual Change Summary” inside the back cover
of this manual.

CONTENTS

	PAGE
SAFETY:	1-4
SAFETY PRECAUTIONS.....	1
HAZARDS/SAFEGUARDS.....	2-3
INTRODUCTION:	5-8
DESCRIPTION.....	5
SPECIFICATIONS.....	5
COLOR STACK SELECTION CHART.....	6
PRE-ENGINEERED COLOR VALVE STACK ASSEMBLIES.....	7
INSTALLATION:	9-10
INSTALLATION.....	9-10
OPERATION:	11-12
OPERATION.....	11
MAINTENANCE:	13-16
MAINTENANCE.....	13-14
TROUBLESHOOTING GUIDE.....	15
PARTS IDENTIFICATION:	17-24
COLOR VALVE STACK / PARTS LIST.....	17-18
COLOR VALVE STACK ASSEMBLY MODEL IDENTIFICATION.....	19-21
CCV-403-SS CUTAWAY / PARTS LIST.....	23-24
ACCESSORIES.....	24
WARRANTY POLICIES:	25
LIMITED WARRANTY.....	25

SAFETY

SAFETY PRECAUTIONS

Before operating, maintaining or servicing any ITW Ransburg electrostatic coating system, read and understand all of the technical and safety literature for your ITW Ransburg products. This manual contains information that is important for you to know and understand. This information relates to **USER SAFETY** and **PREVENTING EQUIPMENT PROBLEMS**. To help you recognize this information, we use the following symbols. Please pay particular attention to these sections.

A WARNING! states information to alert you to a situation that might cause serious injury if instructions are not followed.

A CAUTION! states information that tells how to prevent damage to equipment or how to avoid a situation that might cause minor injury.

A NOTE is information relevant to the procedure in progress.

While this manual lists standard specifications and service procedures, some minor deviations may be found between this literature and your equipment. Differences in local codes and plant requirements, material delivery requirements, etc., make such variations inevitable. Compare this manual with your system installation drawings and appropriate ITW Ransburg equipment manuals to reconcile such differences.

Careful study and continued use of this manual will provide a better understanding of the equipment and process, resulting in more efficient operation, longer trouble-free service and faster, easier troubleshooting. If you do not have the manuals and safety literature for your Ransburg system, contact your local ITW Ransburg representative or ITW Ransburg.



WARNING



► The user **MUST** read and be familiar with the Safety Section in this manual and the ITW Ransburg safety literature therein identified.

► This manual **MUST** be read and thoroughly understood by **ALL** personnel who operate, clean or maintain this equipment! Special care should be taken to ensure that the **WARNINGS** and safety requirements for operating and servicing the equipment are followed. The user should be aware of and adhere to **ALL** local building and fire codes and ordinances as well as **NFPA-33 SAFETY STANDARD**, prior to installing, operating, and/or servicing this equipment.

WARNING

► The hazards shown on the following page may occur during the normal use of this equipment. Please read the hazard chart beginning on page 2.

AREA Tells where hazards may occur.	HAZARD Tells what the hazard is.	SAFEGUARDS Tells how to avoid the hazard.
<p>Spray Area</p> 	<p>Fire Hazard</p> <p>Improper or inadequate operation and maintenance procedures will cause a fire hazard.</p>	<p>Fire extinguishing equipment must be present in the spray area and tested periodically.</p> <p>Spray areas must be kept clean to prevent the accumulation of combustible residues.</p> <p>Smoking must never be allowed in the spray area.</p> <p>When using solvents for cleaning:</p> <p>Those used for equipment flushing should have flash points equal to or higher than those of the coating material.</p> <p>Those used for general cleaning must have flash points above 100°F (37.8°C).</p> <p>Spray booth ventilation must be kept at the rates required by NFPA-33, OSHA, and local codes. In addition, ventilation must be maintained during cleaning operations using flammable or combustible solvents.</p> <p>Electrostatic arcing must be prevented.</p> <p>Test only in areas free of combustible material.</p> <p>Non-factory replacement parts or unauthorized equipment modifications may cause fire or injury.</p> <p>Never use equipment intended for use in waterborne installations to spray solvent based materials.</p> <p>The paint process and equipment should be set up and operated in accordance with NFPA-33, NEC, and OSHA requirements.</p>
<p>General Use and Maintenance</p> 	<p>Improper operation or maintenance may create a hazard.</p> <p>Personnel must be properly trained in the use of this equipment.</p>	<p>Personnel must be given training in accordance with the requirements of NFPA-33.</p> <p>Instructions and safety precautions must be read and understood prior to using this equipment.</p> <p>Comply with appropriate local, state, and national codes governing ventilation, fire protection, operation maintenance, and housekeeping. Reference OSHA, NFPA-33, and your insurance company requirements.</p>

AREA Tells where hazards may occur.	HAZARD Tells what the hazard is.	SAFEGUARDS Tells how to avoid the hazard.
<p>Explosion Hazard/ Incompatible Materials</p> 	<p>Halogenated hydrocarbon solvents for example: methylene chloride and 1,1,1,-Trichloroethane are not chemically compatible with the aluminum that might be used in many system components. The chemical reaction caused by these solvents reacting with aluminum can become violent and lead to an equipment explosion.</p>	<p>Aluminum is widely used in other spray application equipment - such as material pumps, regulators, triggering valves, etc. Halogenated hydrocarbon solvents must never be used with aluminum equipment during spraying, flushing, or cleaning. Read the label or data sheet for the material you intend to spray. If in doubt as to whether or not a coating or cleaning material is compatible, contact your material supplier. Any other type of solvent may be used with aluminum equipment.</p>
<p>Toxic Substances</p> 	<p>Certain material may be harmful if inhaled, or if there is contact with the skin.</p>	<p>Follow the requirements of the Material Safety Data Sheet supplied by coating material manufacturer.</p> <p>Adequate exhaust must be provided to keep the air free of accumulations of toxic materials.</p> <p>Use a mask or respirator whenever there is a chance of inhaling sprayed materials. The mask must be compatible with the material being sprayed and its concentration. Equipment must be as prescribed by an industrial hygienist or safety expert, and be NIOSH approved.</p>

NOTES

INTRODUCTION

DESCRIPTION

CCV-5100 Color Valve Stack

The **CCV-5100 Color Valve Stack** is a manually controlled pneumatic color change valve assembly. The stack allows for up to and including 30 different colors. Color changes are made using CCV-403-SS color change valves.

CCV-403-SS Color Valve Stack

The **CCV-403-SS Color Valve Stack** is a pneumatically operated fluid valve designed for use in paint spray application systems. The valve can be used in a variety of other applications. The valve can be used separately for on/off control of paint to a spray atomizer; or, as part of a multi-color manifold assembly where colors can be quickly flushed and changed when a color change is desired. The CCV-403-SS includes a red indicator (visible through holes in the valve body) that can be seen when the valve is turned “on.”

All parts that come in contact with the fluid material are made of either stainless steel or Teflon that is impervious to most solvents. All other parts of the valve are made of brass, stainless steel, nickel-plated brass, or hard coated (anodized) aluminum. The valve is constructed with a smooth, unobstructed fluid path that allows for faster flush cleaning, and also less pressure restriction. The valve body has two fluid inlet ports that allow fluid to circulate through the valve on a continuous basis. A plug is provided when this feature is not to be used. The double inlet ports also allow two valves to be used as a fluid on/off control and dump system.

SPECIFICATIONS

Environmental/Physical

Nominal Dimensions:	See “Color Valve Stack Figure” in the “Parts Identification” section.
----------------------------	---

Mechanical

Air Requirements:	70-100 psig (4.8-6.9 bar) Operating Pressure
--------------------------	---

Air Inlet/Outlet Connections:	1/4-inch OD Tubing
--------------------------------------	--------------------

Fluid Pressure:	300 psig (20.6 bar) maximum
------------------------	--------------------------------

Fluid Inlet:	1/4-inch NPT(F) X 2 port (Fitting installed 3/8-inch OD tubing)
---------------------	--

Fluid Outlet:	1/4-inch NPT(F) X 1 port (Fitting installed 3/8-inch OD tubing)
----------------------	--

Fluid Flow Capacity:	3800 cc/min @ 47 psi pressure drop (Paint viscosity @ 700 centipoise) Varies according to material pressure and viscosity.
-----------------------------	---

Valve Actuation Speed, On-Off Cycle:	55 cycles/min
---	---------------

Colors: Up to and including 30 colors total.

* If CCV valve is used for “Air Push” air leakage may occur if pressure is excessive.

COLOR VALVE STACK SELECTION CHART

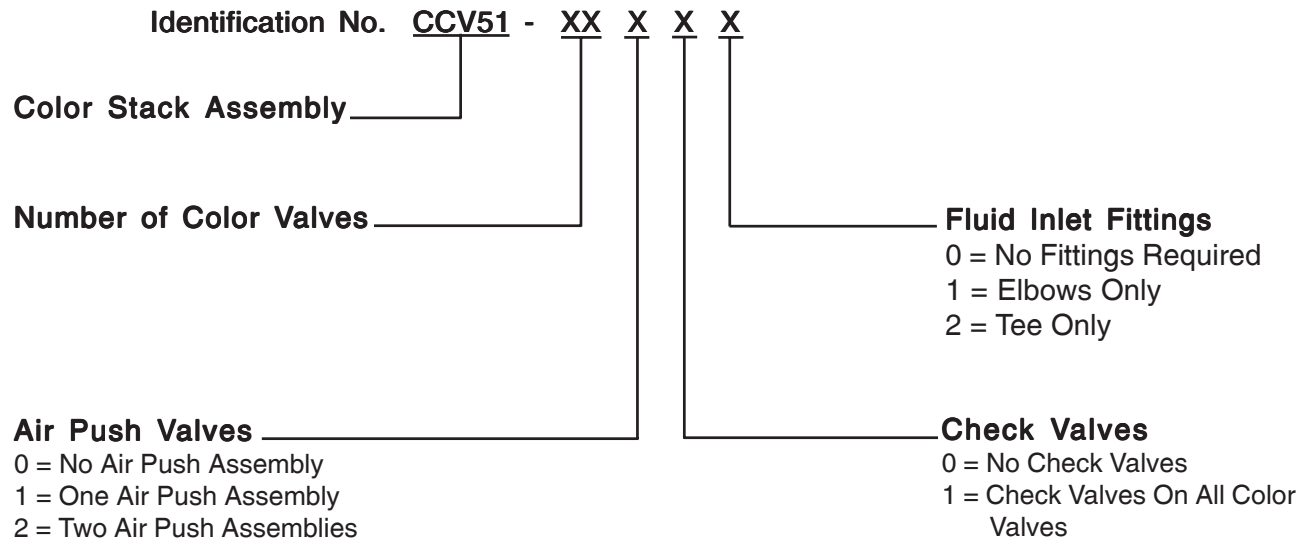

Note: Includes check valve, regulator, and gauge.

PRE-ENGINEERED COLOR VALVE STACK ASSEMBLIES

The following is for “Pre-Engineered Color Valve Stack Assemblies”. Please reference “Color Valve Stack Selection Chart” for the stack assembly number.

Part Number CCV-51XX-XXX identifies the configuration of the stack assembly.

(CCV-51)XX-XXX - Color Stack Assembly

Includes the top block and solvent valve. The solvent valve is always supplied with a check valve and a 3/8-inch ODT stainless steel female elbow for fluid inlet.

CCV-51(XX)-XXX - Number of Color Valves

(Selection 00-30). These two numbers indicate the number of valves required for paint inlet to the stack assembly.

CCV-51XX-(X)XX - Air Push Valves

(Selection 0, 1, 2). This number indicates the number of “air push” valves required. Each valve is supplied with a check valve, gauge, regulator, and 3/8-inch ODT brass push style fitting for air inlet. The air push is used to push out residual paint in the fluid supply line. This air is also pulsed on and off with the solvent to create a scrubbing action. In the event that two different pressures are required, two air push valves can be supplied.

CCV-51XX-X(X)X - Check Valves

(Selection 0, 1). This number indicates whether check valves are supplied on the paint inlet valves. Check valves are used to prevent materials from contaminating each other in the event that two valves would be opened at the same time.

NOTE: Check valves will always be supplied on solvent and air valves, regardless of selection made here.

CCV-51XX-XX(X) - Fluid Inlet Fittings

(Selection 0, 1, 2). This number indicates whether no fitting, elbows, or tees are supplied for the fluid inlet to the color valves. Elbows are typically utilized for fluid inlet. Tees are used for circulating the paint at the color valve. The elbows and tees are stainless steel and accept a 1/4-inch OD fluid line.

All valves are supplied with a brass push style, swivel elbow for the air pilot. This fitting accepts a 1/4-inch OD tube.

NOTES

INSTALLATION

The CCV-403-SS valve mounted at this position is used for solvent flushing of the manifold assembly. Connect the solvent feed line to this valve. (Check valve is always used on input port of CCV).

NOTE:

Check valves are always used on input ports of Air Push and Solvent CCV's They are optional for Color CCV's.

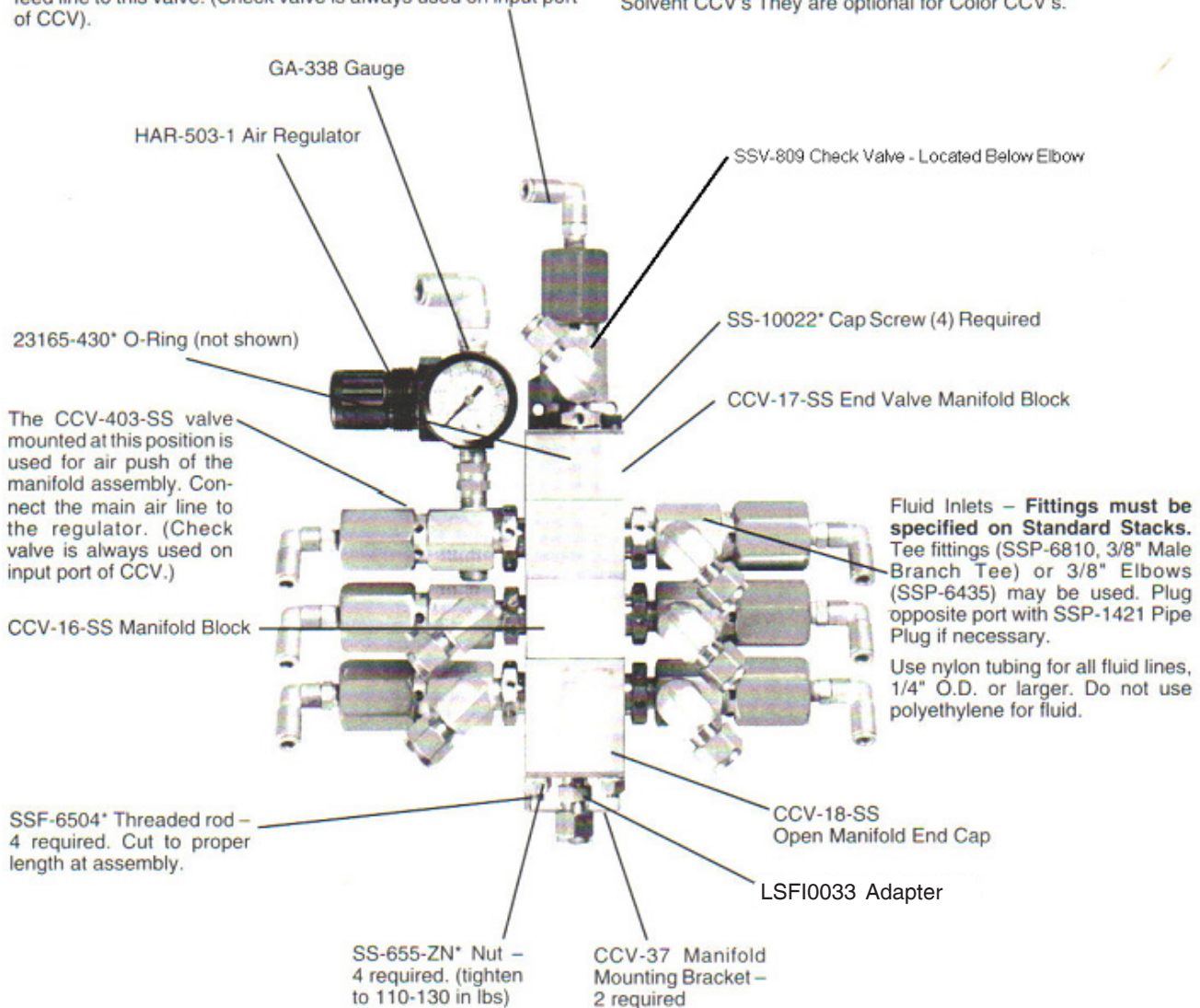

* Included in KK-4901 Manifold Assembly Kit.

Figure 1: Typical Color Change Stack

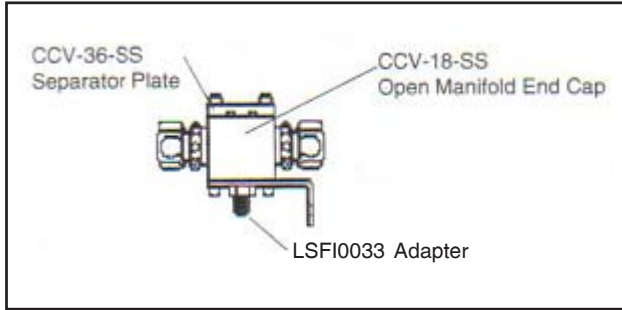

Figure 2: Two Valve Manifold Assembly

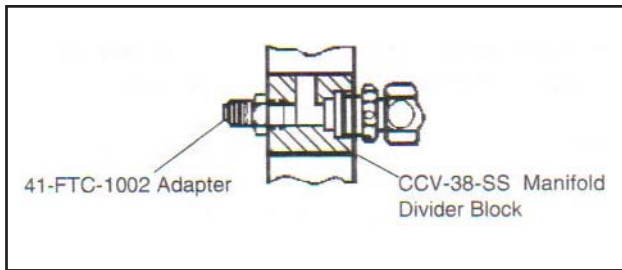

Figure 3: Manifold Divider Block

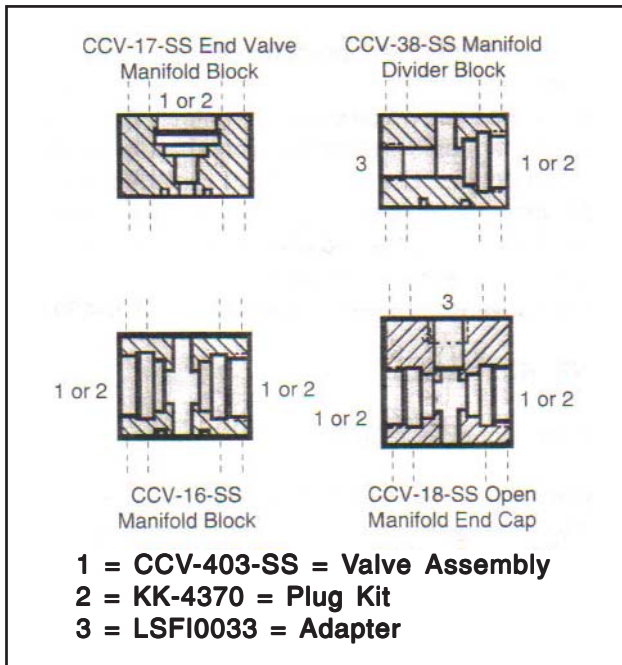

Figure 4: Available Manifold Blocks

Figure 3 shows the four manifold blocks that can be used in a manifold system. In addition, CCV-36-SS separator plate (Figure 2) can also be used. In Figure 4, shown by the block inlets/outlets, are numbers indicating hardware to be installed at these locations. The dotted lines indicate the path of the mounting studs which hold the blocks in place. The o-ring slots are shown (o-rings are not included on CCV-18-SS). O-rings are included in KK-4901 Manifold Assembly Kit.

KK-4901 Manifold Assembly Kit

The kit includes threaded rod, lockwashers, nuts, two (2) mounting brackets, and twelve (12) o-rings which will allow assembly. A spanner tool, part CCV-7, is also included in this kit. This tool inserts into any one of the holes in the spanner nut and is used to tighten or loosen the nut. This is convenient in close clearances where a wrench may not fit.

NOTE

► Tighten CCV-403-SS valve assembly and KK-4370 plug kit (when used) to manifold using 132-156 lbs•in torque. **Do Not Over-Tighten. Use a good quality pipe sealant on all threads of air and fluid connections. Do not use sealant or tape on CCV-403-SS valve when assembling to manifold.**

OPERATION

Installation and Operation

Overview

The coating material is supplied from the users pressurized system that may be a pressure tank, paint circulating system or other suitable pressure paint supply system. 3/8-inch OD fluid tubing is connected between the users paint supply and the CCV.

An air signal supplied to the CCV activates the paint being delivered to the applicator.

NOTES



CAUTION

- ▶ CCV Valve must be supported while tightening the tube fittings to prevent damage to the valve seats, or remove the valve before tightening the fluid inlet fittings.
- ▶ Circulation system lines must have a flexible connection between the “hard piping” and the valve.

NOTES

MAINTENANCE

Cleaning

The valve and associated parts through which fluid passes should be cleaned after use by flushing with an appropriate solvent. While flushing, the valve should be triggered several times in order to flush particles from the seat and stem seal areas.

Wear Parts

Wear parts include the poppet seat, stem, valve needle seal, and piston cup. All of these parts are Teflon except for the stem that is stainless steel. Wear parts should be inspected and replaced on a regular maintenance schedule. The frequency of replacement depends upon cycle rate and material abrasiveness. Valves should be inspected after six months usage. If any parts are worn, or if paint leakage is evident, replace all wear parts with Valve Repair Kit KK-4841.

Valve Removal

1. Disconnect air and fluid lines from valve.
2. Insert the Spanner Tool (CCV-7) into one of the holes in the spanner nut and rotate counterclockwise (as viewed from the rear air inlet fitting in valve). If the Spanner Tool is not available, a 1-1/6-inch open-end wrench can also be used to loosen the spanner nut.

CCV-403-SS Valve Disassembly

1. Remove valve cap (CCV-43) from valve body. Hold hex valve body with 1-1/16" wrench while turning cap counter-clockwise with a 1-1/8-inch wrench.
2. Place 7/16-inch socket on clamping nut (CCV-45), and insert a 9/32-inch socket onto the end of the stem at opposite end of valve (Note: Older style valves used a Phillips screwdriver slot on the end of the stem. Use a Phillips screwdriver in place of nut driver). Rotate the socket counterclockwise until the clamping nut is free from the stem.

NOTE

► The stem should be held steady while the nut is rotated. Rotating the stem can scratch the stem finish causing premature valve needle seal wear and valve leakage.

3. The piston cup (VA-246) is held onto the clamping nut by a brass nut (CCV-3), which has an 11/16-inch hex. Use a 7/16" hex socket and an 11/16-inch wrench to disassemble the nut from the clamping nut so that the Teflon piston cup can be removed.
4. The valve indicator (CCV-42) and piston spring (CCV-41-K2) will be free and can be removed when the clamping nut is off the stem.
5. The stem can now be pulled from the front of the valve body. After the stem is removed, reach into the rear of the valve body and pull out the spring washer (CCV-4) and the needle seal (CCV-8). The poppet seal (CCV-40) that is behind the stem seat can be removed from the body after the stem is removed.

Valve Reassembly

Reassemble the CCV-403-SS valve in reverse order, but follow these additional instructions:

1. Use Loctite (medium strength, Loctite grade #242) on the threads of the clamping nut (2) and stem (13) as shown on the parts breakdown in Figure 6.
2. With stem fully inserted into assembly, tighten the clamping nut onto the stem and torque to specifications shown in "CCV-403-SS Cutaway Parts List Note" in the "Parts Identification" section. **Do not rotate the stem during assembly.**

3. Apply a thin film of lubricant (light grease type) to the valve cap bore and cup as shown in “Figure 6” in the “Parts Identification” section. Tighten the valve cap to the torque specification shown “CCV-403-SS Cutaway Parts List Note” in the “Parts Identification” section.

NOTE

► Make sure all seating surfaces of the stem, poppet seat, needle seal, and cup are clean and free of nicks and scratches to prevent leakage.

Manifold Reassembly

1. When reinstalling the CCV-403-SS back into the manifold block or valve adapter, torque the spanner nut to 132-156 lbs•in. **Do not over-tighten.**

2. If the manifold blocks are disassembled, do not reuse o-ring 23165-430 which goes between each block. Replace with new o-rings. Reusing the old o-rings may cause leakage.

3. Torque the four SS-655-ZN nuts (which hold the manifold blocks together) to 110-130 lbs•in.

4. When reinstalling air and fluid connections, use a good quality pipe sealant on the threads. However, do not use sealant or tape on the spanner nut threads when installing the CCV-403-SS valve into the manifold block or valve adapter.

NOTES

TROUBLESHOOTING GUIDE

General Problem	Possible Cause	Solution
DELIVERY		
Fluid	1. No main supply air 2. No paint connected to CCV 3. Paint not pressurized	1. Turn supply air on. 2. Reconnect paint. 3. Check users supply.
Air (to CCV)	1. No main supply air 2. Loose connection	1. Turn supply air On. 2. Tighten connections.
LEAKAGE		
Air	1. Hole in tubing 2. Loose connections	1. Replace worn tubing. 2. Tighten connections.
Fluid	1. Loose connection 2. Worn fluid tubing	1. Tighten connections. 2. Replace worn fluid tubing.
DEFICIENT DELIVERY		
Air	1. Insufficient supply air	1. Check air regulator.
Fluid	1. Low supply pressure 2. Clogged or obstructed fluid lines 3. Clogged or obstructed CCV stack	1. Increase supply pressure. 2. Clean or replace. 3. Clean as required.

NOTES

PARTS IDENTIFICATION

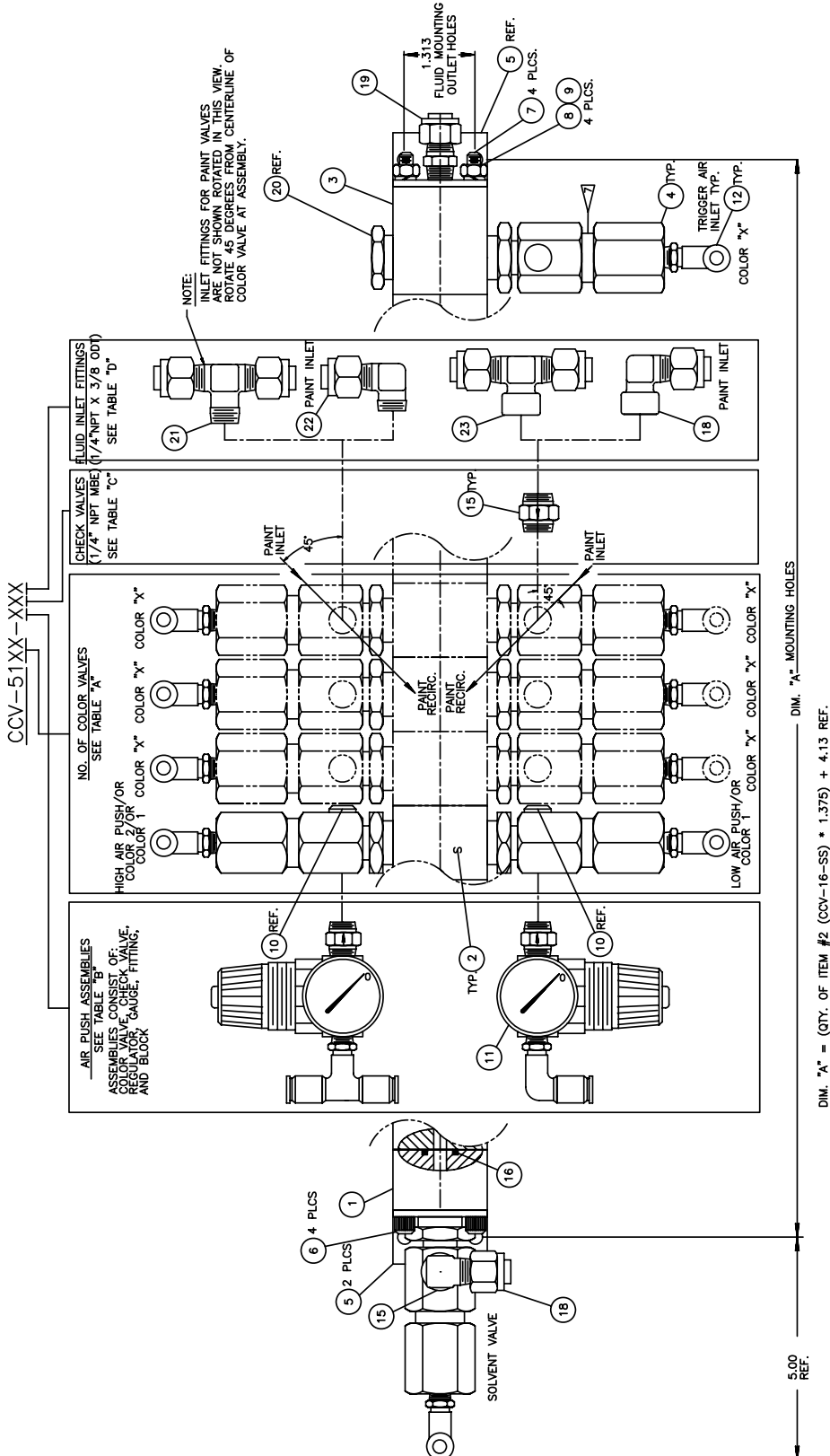

Figure 5: Color Valve Stack

COLOR VALVE STACK - PARTS LIST (Figure 5)			
Item #	Part #	Description	Qty.
1	CCV-17-SS	Manifold Block	1
2	CCV-16-SS	Manifold Block	1
3	CCV-18-SS	Manifold Block	1
4	CCV-403-SS	Color Valve Assembly	Table A - "H"
5	CCV-37	Bracket	2
6	SS-10022	Cap Screw	4
7	SSF-6504	Threaded Rod (Cut to suit)	Table A - "G"
8	SS-655-ZN	Hex Nut	4
9	SS-1505-CD	Lockwasher	4
10	SSP-1421	Pipe Plug (Included with valve assemblies)	Ref.
11	Table B - "K"	Air Push Assembly	1
12	SSP-6427	Male, Swivel Elbow	Table A - "H"
13	----	----	--
14	----	----	--
15	SSV-809	Check Valve, 1/4" NPT, MBE, Solventborne	Table C - "J"
16	23165-430	O-Ring	Table A - "L"
17	----	----	--
18	SSP-6443	Female Elbow, 3/8" ODT X 1/4" NPT, SS	Table D - "M"
19	LSFI0033-00	Connector, 3/8" ODT X 3/8" AN, SS	1
20	KK-4370	Plug Kit	Table A - "E"
21	SSP-6810	Male Tee, 3/8" ODT X 1/4" NPT, SS	Table D - "N"
22	SSP-6435	Male Elbow, 3/8" ODT X 1/4" NPT, SS	Table D - "O"
23	SSP-6812	Female Tee, 3/8" ODT X 1/4" NPT, SS	Table D - "P"
24	----	----	--
25	CCV-7	Valve Tool (Included but not shown)	1
26	LN-9100-00	Literature (Included but not shown)	1
27	A11846-00	Caution Tag (Included but not shown)	1

COLOR VALVE STACK ASSEMBLY MODEL IDENTIFICATION

When ordering, use CCV-51AA-BCD as indicated by Tables A thru D.
Three characters must follow the basic part number:

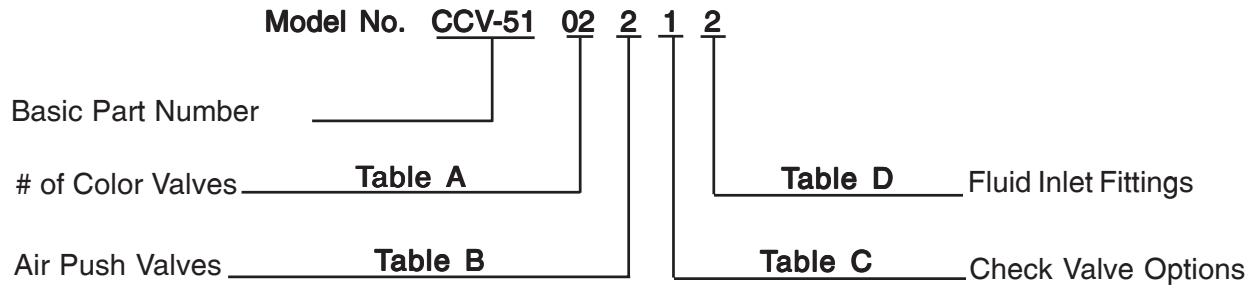

Table "A" - Number of Color Valves						
Dash #	Description	"E"	"F"	"G" x(4)	"H"	"L"
00	No Color	0	0	3"	1	1
01	One Color	1	0	3"	2	1
02	Two Color	0	0	3"	3	1
03	Three Color	1	1	4-3/8"	4	2
04	Four Color	0	1	4-3/8"	5	2
05	Five Color	1	2	5-3/4"	6	3
06	Six Color	0	2	5-3/4"	7	3
07	Seven Color	1	3	7-1/8"	8	4
08	Eight Color	0	3	7-1/8"	9	4
09	Nine Color	1	4	8-1/2"	10	5
10	Ten Color	0	4	8-1/2"	11	5
11	Eleven Color	1	5	9-7/8"	12	6
12	Twelve Color	0	5	9-7/8"	13	6
13	Thirteen Color	1	6	11-1/4"	14	7
14	Fourteen Color	0	6	11-1/4"	15	7
15	Fifteen Color	1	7	12-5/8"	16	8
16	Sixteen Color	0	7	12-5/8"	17	8
17	Seventeen Color	1	8	14"	18	9
18	Eighteen Color	0	8	14"	19	9
19	Nineteen Color	1	9	15-3/8"	20	10
20	Twenty Color	0	9	15-3/8"	21	10
21	Twenty-One Color	1	10	16-3/4"	22	11
22	Twenty-Two Color	0	10	16-3/4"	23	11
23	Twenty-Three Color	1	11	18-1/8"	24	12
24	Twenty-Four Color	0	11	18-1/8"	25	12
25	Twenty-Five Color	1	12	19-1/2"	26	13
26	Twenty-Six Color	0	12	19-1/2"	27	13
27	Twenty-Seven Color	1	13	20-7/8"	28	14
28	Twenty-Eight Color	0	13	20-7/8"	29	14
29	Twenty-Nine Color	1	14	22-1/4"	30	15
30	Thirty Color	0	14	22-1/4"	31	15

Table B - Air Push Valves		
Dash #	Description	"K"
0	No Air Push Assembly	--
1	One Air Push Assembly	79309-01
2	Two Air Push Assemblies	79309-02

Table C - Check Valve Options						
Dash #	Description	"J"	"R"	"S"	"T"	"U"
0	No Check Valves On Color Valves	1	0	Table A-"H"	Table A-"H"	0
1	Check Valves On All Color Valves	Table A-"H"	Table A-"H"	0	0	Table A-"H"

Table D- Fluid Inlet Fittings					
Dash #	Description	"M"	"N"	"O"	"P"
0	No Fittings	0	0	0	0
1	Elbows Only	Table C-"R"	0	Table C-"S"	0
2	Tees Only	0	Table C-"T"	0	Table C-"U"

NOTES

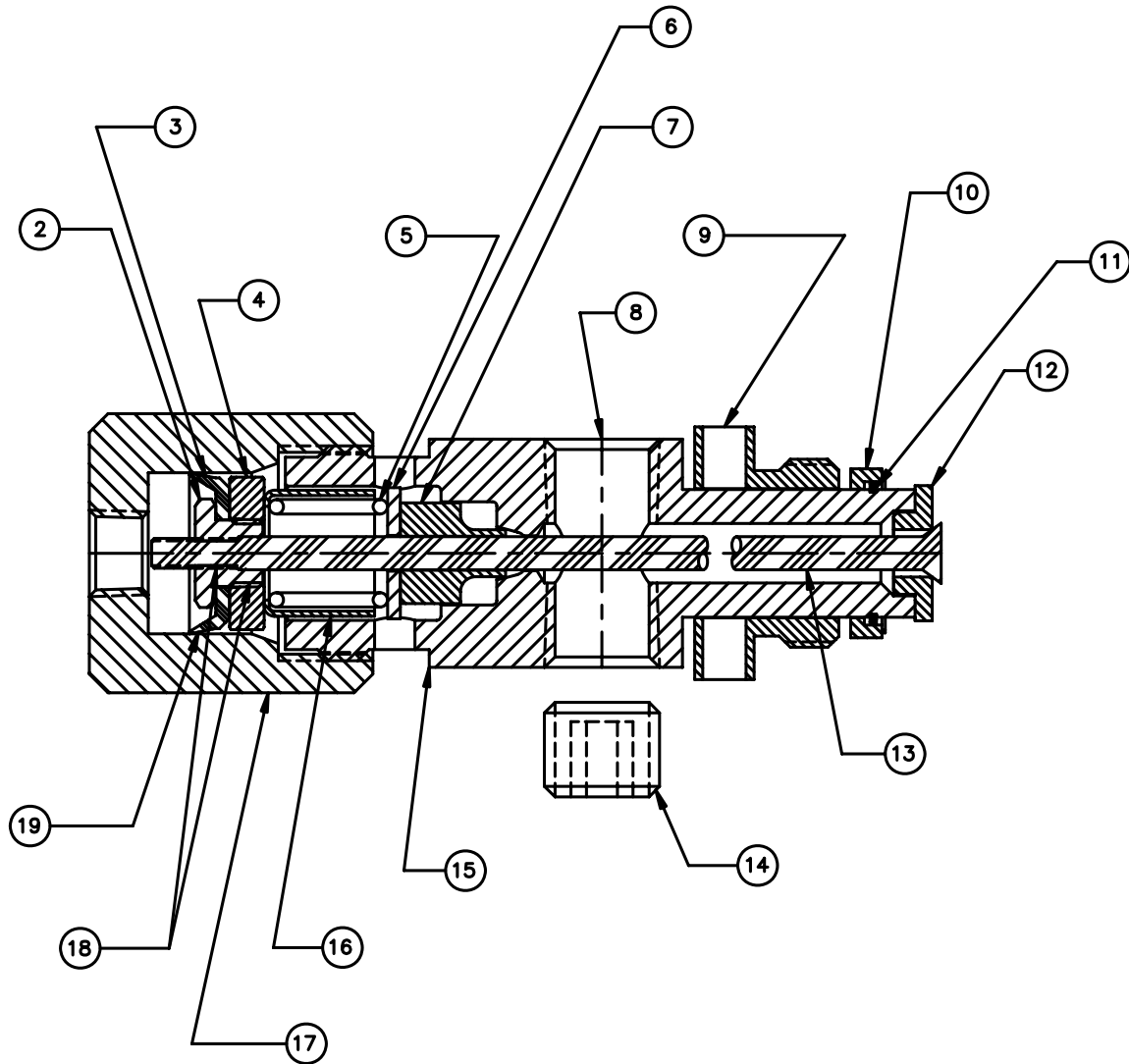

Figure 6: CCV-403-SS Cutaway

CCV-403-SS CUTAWAY - PARTS LIST (Figure 6)		
Item #	Part #	Description
1	----	Air Inlet, 1/8" NPT (F)
2	CCV-45	Clamping Nut *
3	VA-246	Cup *
4	CCV-3	Nut
5	CCV-41-K2	Spring Kit
6	CCV-4	Spring Washer
7	CCV-8-K2	Valve Needle Seal Kit *
8	----	Fluid Inlet (2 ports), 1/4" NPT (F)
9	CCV-13	Spanner Nut
10	CCV-44	Ring Retainer
11	SST-8436-K5	Retaining Ring Kit
12	CCV-40-K2	Poppet Seat Kit *
13	CCV-39	Stem (Order KK-4841) *
14	SSP-1421	Pipe Plug (Shipped loose with valve) (Not used if material is recirculated)
15	CCV-15-SS	Valve Body
16	CCV-42	Valve Indicator
17	CCV-43	Valve Cap
18	----	Use Loctite (Medium Strength, Grade #242) on threads - 2 places
19	----	Apply a thin film of lubricant (light grease) to bore and cup at assembly.
--	CCV-7	Spanner Tool (Not Shown)

* Supplied in Repair Kit KK-4841.

Note: Tighten CCV-45 to CCV-3 with VA-246 in between, using 12-18 lbs•in torque.
Tighten CCV-45, CCV-3, VA-246 assembly to CCV-39 using 3 lbs•in torque maximum (finger tight). **Do Not Over-Tighten.**

ACCESSORIES	
Part #	Description
KK-4901	Paint Manifold Assembly Kit

WARRANTY POLICIES

LIMITED WARRANTY

ITW Ransburg will replace or repair without charge any part and/or equipment that falls within the specified time (see below) because of faulty workmanship or material, provided that the equipment has been used and maintained in accordance with ITW Ransburg's written safety and operating instructions, and has been used under normal operating conditions. Normal wear items are excluded.

THE USE OF OTHER THAN ITW RANSBURG APPROVED PARTS, VOID ALL WARRANTIES.

SPARE PARTS: One hundred and eighty (180) days from date of purchase, except for rebuilt parts (any part number ending in "R") for which the warranty period is ninety (90) days.

EQUIPMENT: When purchased as a complete unit, (i.e., guns, power supplies, control units, etc.), is one (1) year from date of purchase. **WRAPPING THE APPLICATOR IN PLASTIC, ASSOCIATED VALVES AND TUBING, AND SUPPORTING HARDWARE IN PLASTIC, SHRINK-WRAP, OR ANY OTHER NON-APPROVED COVERING, WILL VOID THIS WARRANTY.**

ITW RANSBURG'S ONLY OBLIGATION UNDER THIS WARRANTY IS TO REPLACE PARTS THAT HAVE FAILED BECAUSE OF FAULTY WORKMANSHIP OR MATERIALS. THERE ARE NO IMPLIED WARRANTIES NOR WARRANTIES OF EITHER MERCHANTABILITY OR FITNESS FOR A PARTICULAR PURPOSE. ITW RANSBURG ASSUMES NO LIABILITY FOR INJURY, DAMAGE TO PROPERTY OR FOR CONSEQUENTIAL DAMAGES FOR LOSS OF GOODWILL OR PRODUCTION OR INCOME, WHICH RESULT FROM USE OR MISUSE OF THE EQUIPMENT BY PURCHASER OR OTHERS.

EXCLUSIONS:

If, in ITW Ransburg's opinion the warranty item in question, or other items damaged by this part was improperly installed, operated or maintained, ITW Ransburg will assume no responsibility for repair or replacement of the item or items. The purchaser, therefore will assume all responsibility for any cost of repair or replacement and service related costs if applicable.

MANUAL CHANGE SUMMARY

This manual was published to supercede Service Manuals **LN-9113-06** Color Valve Stack to make the following changes:

1. Added "Service Manual Price: €25.00 (Euro)" to the "Front Cover".
2. Revised "Figure 1 - Typical Color Change Stack" in the "Installation" section.
3. Revised "Figure 2 - Two Valve Manifold Assembly" in the "Installation" section.
4. Revised "Figure 4 - Available Manifold Block" in the "Installation" section.
5. Revised "Color Valve Stack Parts List - Item 19 - LSF10033-00" in the "Parts Identification" section.
6. Added "Accessories - KK-4901 Paint Manifold Assembly Kit" in the "Parts Identification" section.
7. Removed "Appendix" section. See literature IL-307 Technical Supplement for All Products".
8. Added "Service Manual Price: €25.00 (Euro)" to the "Back Cover".

Service Manual Price: €25.00 (Euro)
\$30.00 (U.S.)

Manufacturing

1910 North Wayne Street
Angola, Indiana 46703-9100
Telephone: 260/665-8800
Fax: 260/665-8516

Technical/Service Assistance

Automotive Assembly and Tier I
Industrial Systems
Ransburg Guns
www.itwransburg.com

Telephone: 800/ 626-3565 Fax: 419/ 470-2040
Telephone: 800/ 233-3366 Fax: 419/ 470-2071
Telephone: 800/ 233-3366 Fax: 419/ 470-2071

Technical Support Representative will direct you to the appropriate telephone number for ordering Spare Parts.

