

VECTOR SOLO™ APPLICATORS

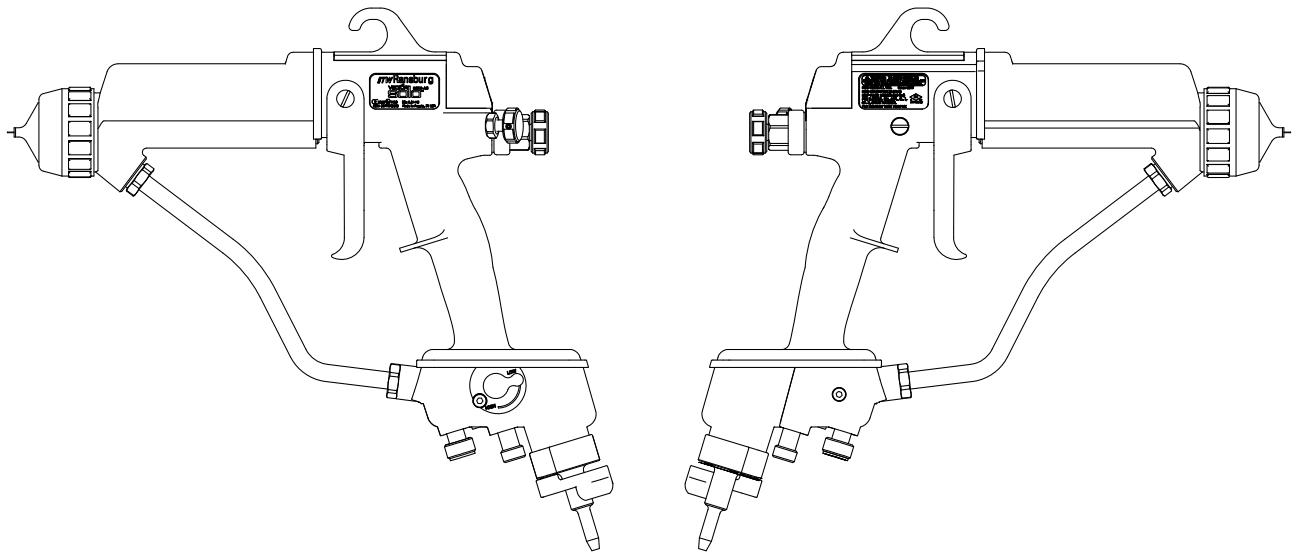

MODEL: 79900 Solventborne RS90-AS



IMPORTANT: Before using this equipment, carefully read **SAFETY PRECAUTIONS**, starting on page 1, and all instructions in this manual. Keep this Service Manual for future reference.

Service Manual Price: €40.00 (Euro)
\$50.00 (U.S.)

NOTE: This manual has been changed from revision AH-08-01.7 to revision AH-08-01.8.
Reasons for this change are noted under “Manual Change Summary” inside the back cover
of this manual.

CONTENTS

	PAGE
SAFETY:	1-4
SAFETY PRECAUTIONS.....	1
HAZARDS / SAFEGUARDS.....	2-4
ATEX/FM:	5-8
EUROPEAN ATEX DIRECTIVE.....	5
EUROPEAN ATEX LABELS.....	6
FM CONFIGURATION DRAWING.....	7-8
INTRODUCTION:	9-12
GENERAL DESCRIPTION.....	9
79900 VECTOR SOLO SOLVENTBORNE SPECIFICATIONS.....	10
VECTOR SOLO SOLVENTBORNE ELECTROSTATIC SPRAY APPLICATOR.....	11
VECTOR SOLO TYPICAL SOLVENTBORNE INSTALLATION.....	12
INSTALLATION:	13-16
79900 VECTOR SOLO SOLVENTBORNE INSTALLATION.....	13-14
INSTALLATION.....	14-16
OPERATION:	17-20
OPERATION.....	17-18
FLUSHING / COLOR CHANGE PROCEDURE.....	18-19
FLUID NOZZLE / AIR CAP.....	20
MAINTENANCE:	21-41
SUITABLE SOLVENTS FOR CLEANING VECTOR SOLO APPLICATORS.....	21
ROUTINE SCHEDULE.....	22-23
APPLICATOR REPAIR.....	23-24
AIR CAP.....	24
FLUID NOZZLE.....	25-26
NEEDLE / ELECTRODE.....	26
NEEDLE / ELECTRODE RESISTANCE TESTING.....	27
BARREL REMOVAL.....	27-30
NEEDLE SHAFT REMOVAL / REPLACEMENT.....	31-32
POWER MODULE REMOVAL.....	32-33
HANDLE DISASSEMBLY.....	33-35
POWER MODULE-FLUID FITTING REMOVAL.....	35-36
TEST AND MAINTENANCE KIT USAGE (79870-00).....	37-39
TROUBLESHOOTING GUIDE.....	41

(Continued On Next Page)

CONTENTS (Cont.)

	PAGE
PARTS IDENTIFICATION:	42-56
<hr/>	
VECTOR SOLO APPLICATORS PARTS	
BREAKDOWN / PARTS LIST.....	42-46
VECTOR SOLO MODELS AVAILABLE.....	44
79853-00 NEEDLE SHAFT 2K ADJUSTABLE PACKINGS PARTS / PARTS LIST.....	46
79853-01 NEEDLE SHAFT 1K NONADJUSTABLE PACKINGS PARTS / PARTS LIST.....	47
POWER MODULE REPLACEABLE PARTS / PARTS LIST.....	47
ACCESSORIES / PARTS LIST.....	48-49
SHORT STOPPER HOSE ASSEMBLY.....	50-53
PARTS COMPARISON / TRANS-TECH. ATOMIZATION PARTS LIST.....	54
79555 TRANS-TECH. CONVERSION KITS AVAILABLE.....	55
VECTOR SOLO RECOMMENDED SPARE PARTS.....	56
<hr/>	
WARRANTY POLICIES:	58
<hr/>	
LIMITED WARRANTY.....	58

SAFETY

SAFETY PRECAUTIONS

Before operating, maintaining or servicing any ITW Ransburg electrostatic coating system, read and understand all of the technical and safety literature for your ITW Ransburg products. This manual contains information that is important for you to know and understand. This information relates to **USER SAFETY** and **PREVENTING EQUIPMENT PROBLEMS**. To help you recognize this information, we use the following symbols. Please pay particular attention to these sections.

A WARNING! states information to alert you to a situation that might cause serious injury if instructions are not followed.

A CAUTION! states information that tells how to prevent damage to equipment or how to avoid a situation that might cause minor injury.

A NOTE is information relevant to the procedure in progress.

While this manual lists standard specifications and service procedures, some minor deviations may be found between this literature and your equipment. Differences in local codes and plant requirements, material delivery requirements, etc., make such variations inevitable. Compare this manual with your system installation drawings and appropriate Ransburg equipment manuals to reconcile such differences.

Careful study and continued use of this manual will provide a better understanding of the equipment and process, resulting in more efficient operation, longer trouble-free service and faster, easier troubleshooting. If you do not have the manuals and safety literature for your ITW Ransburg system, contact your local ITW Ransburg representative or ITW Ransburg.



WARNING



- ▶ The user **MUST** read and be familiar with the Safety Section in this manual and the ITW Ransburg safety literature therein identified.
- ▶ This hand held device is intended to be used by trained personnel **ONLY**.
- ▶ This manual **MUST** be read and thoroughly understood by **ALL** personnel who operate, clean or maintain this equipment! Special care should be taken to ensure that the **WARNINGS** and safety requirements for operating and servicing the equipment are followed. The user should be aware of and adhere to **ALL** local building and fire codes and ordinances as well as **NFPA-33 SAFETY STANDARD, or applicable country safety standards** prior to installing, operating, and/or servicing this equipment.

WARNING

- ▶ The hazards shown on the following page may occur during the normal use of this equipment. Please read the hazard chart beginning on page 2.

AREA Tells where hazards may occur.	HAZARD Tells what the hazard is.	SAFEGUARDS Tells how to avoid the hazard.
<p>Spray Area</p> 	<p>Fire Hazard</p> <p>Improper or inadequate operation and maintenance procedures will cause a fire hazard.</p> <p>Protection against inadvertent arcing that is capable of causing fire or explosion is lost if any safety interlocks are disabled during operation. Frequent power supply shutdown indicates a problem in the system requiring correction.</p>	<p>Fire extinguishing equipment must be present in the spray area and tested periodically.</p> <p>Spray areas must be kept clean to prevent the accumulation of combustible residues.</p> <p>Smoking must never be allowed in the spray area.</p> <p>The high voltage supplied to the atomizer must be turned off prior to cleaning, flushing or maintenance.</p> <p>When using solvents for cleaning:</p> <p>Those used for equipment flushing should have flash points equal to or higher than those of the coating material.</p> <p>Those used for general cleaning must have flash points above 100°F (37.8°C).</p> <p>Spray booth ventilation must be kept at the rates required by local and/or country codes. In addition, ventilation must be maintained during cleaning operations using flammable or combustible solvents.</p> <p>Electrostatic arcing must be prevented.</p> <p>Test only in areas free of combustible material.</p> <p>Testing may require high voltage to be on, but only as instructed.</p> <p>Non-factory replacement parts or unauthorized equipment modifications may cause fire or injury.</p> <p>If used, the key switch bypass is intended for use only during setup operations. Production should never be done with safety interlocks disabled.</p> <p>The paint process and equipment should be set up and operated in accordance with local and/or country safety codes.</p>

AREA Tells where hazards may occur.	HAZARD Tells what the hazard is.	SAFEGUARDS Tells how to avoid the hazard.
Toxic Substances 	Certain material may be harmful if inhaled, or if there is contact with the skin.	Follow the requirements of the Material Safety Data Sheet supplied by coating material manufacturer. Adequate exhaust must be provided to keep the air free of accumulations of toxic materials. Use a mask or respirator whenever there is a chance of inhaling sprayed materials. The mask must be compatible with the material being sprayed and its concentration. Equipment must be as prescribed by an industrial hygienist or safety expert, and be approved.
Explosion Hazard / Incompatible Materials 	Halogenated hydrocarbon solvents, for example: methylene chloride and 1,1,1, - Trichloroethane, are not chemically compatible with the aluminum that might be used in many system components. The chemical reaction caused by these solvents reacting with aluminum can become violent and lead to an equipment explosion.	Spray applicators require that aluminum inlet fittings be replaced with stainless steel. (See "Accessories" list) Aluminum is widely used in other spray application equipment - such as material pumps, regulators, valves, etc. Check all other equipment items before use and make sure they can also be used safely with these solvents. Read the label or data sheet for the material you intend to spray. If in doubt as to whether or not a coating or cleaning material is compatible, contact your material supplier. Any other type of solvent may be used with aluminum equipment.
Electrical Equipment 	High voltage equipment is utilized. Arcing in areas of flammable or combustible materials may occur. Personnel are exposed to high voltage during operation and maintenance. Protection against inadvertent arcing that may cause a fire or explosion is lost if safety circuits are disabled during operation. An electrical arc can ignite coating materials and cause a fire or explosion.	Turn the power module OFF before working on the equipment. Test only in areas free of flammable or combustible material. Testing may require high voltage to be on, but only as instructed. Production should never be done with the safety circuits disabled. Before turning the high voltage on, make sure no objects are within the sparking distance.

AREA Tells where hazards may occur.	HAZARD Tells what the hazard is.	SAFEGUARDS Tells how to avoid the hazard.
<p>Spray Area</p> 	<p>Electrostatic Arcing</p>	<p>Never operate the applicator without properly grounding the following.</p> <p>A. Operators</p> <p>Operators must be grounded. Rubber soled insulating shoes should not be worn. Grounding leg or wrist straps may be used.</p> <p>Operators must maintain contact with the handle of the applicator. If work gloves are used, the palm section must be cut out.</p> <p>Operators must remove from themselves all metal objects that are not grounded.</p> <p>NOTE: REFER TO NFPA-33 REGARDING OPERATOR GROUNDING OR SPECIFIC COUNTRY SAFETY CODE.</p> <p>B. Parts being sprayed. Resistance between the part and a grounded conveyor must not exceed 1 megohm.</p> <p>C. Every metal and conductive object in the spray area. This includes the booth, parts hangers, fire extinguishers, conductive flooring, etc.</p> <p>Grounded conductive flooring must be provided in the spray area.</p> <p>Turn off voltage at the power module before flushing out, cleaning, or removing any parts from the applicator.</p> <p>Never install an applicator into a fluid system using an isolated solvent supply.</p> <p>Do not touch applicator electrode while applicator is energized.</p>
<p>General Use and Maintenance</p> 	<p>Improper operation or maintenance may create a hazard.</p> <p>Personnel must be properly trained in the use of this equipment.</p>	<p>Personnel must be given training in accordance with the requirements of NFPA-33.</p> <p>Instructions and safety precautions must be read and understood prior to using this equipment.</p> <p>Comply with appropriate local, state, and national codes governing ventilation, fire protection, operation maintenance, and housekeeping.</p>

EUROPEAN ATEX DIRECTIVE 94/9/EC, ANNEX II, 1.0.6

The following instructions apply to equipment covered by certificate number Sira 08ATEX5060:

1. The equipment may be used with flammable gases and vapors with apparatus groups II and with temperature class T6.
2. The equipment is only certified for use in ambient temperatures in the range 0°C to +40°C and should not be used outside this range.
3. Installation shall be carried out by suitably trained personnel in accordance with the applicable code of practice e.g. EN 60079-14:1997.
4. Inspection and maintenance of this equipment shall be carried out by suitably trained personnel in accordance with the applicable code of practice e.g. EN 60079-17.
5. Repair of this equipment shall be carried out by suitable trained personnel in accordance with the applicable code of practice e.g. EN 60079-19.
6. Putting into service, use, assembling, and adjustment of the equipment shall be fitted by suitably trained personnel in accordance with the manufacturer's documentation.

Refer to the "Table of Contents" of this service manual:

- a. Installation
- b. Operation
- c. Maintenance
- d. Parts Identification

7. Components to be incorporated into or used as replacement parts of the equipment shall be fitted by suitably trained personnel in accordance with the manufacturer's documentation.

8. The certification of this equipment relies upon the following materials used in its construction:

If the equipment is likely to come into contact with aggressive substances, then it is the responsibility of the user to take suitable precautions that prevent it from being adversely affected, thus ensuring that the type of protection provided by the equipment is not compromised.

Aggressive substances: e.g. acidic liquids or gases that may attack metals, or solvents that may affect polymeric materials.

Suitable precautions: e.g. regular checks as part of routine inspections or establishing from the material's data sheets that it is resistant to specific chemicals.

Refer to "Specifications" in the "Introduction" section:

- a. All fluid passages contain stainless steel or nylon fittings.
- b. High voltage cascade is encapsulated with a solvent resistant epoxy.

9. A recapitulation of the certification marking is detailed in the "ATEX" section, on the next page, drawing numbers: 79846-00 and 79852-00.

10. The characteristics of the equipment shall be detailed e.g. electrical, pressure, and voltage parameters.

The manufacturer should note that, on being put into service, the equipment must be accompanied by a translation of the instructions in the language or languages of the country in which the equipment is to be used and by the instructions in the original language.

Vector Solo 79900 ATEX Product Marking Definitions

Ex Certificate Number: Sira 08ATEX5060

Sira = Notified Body performing EC-type examination

08 = Year of certification

ATEX = Reference to ATEX Directive

5 = Protection Concept Code (code 5 is titled Encapsulation)

060 = Document serial number

X = Special conditions for safe use apply

Special conditions for safe use: The Vector Solo 79900 Applicators shall only be used with associated Air Hose Assembly.

Product Marking



Ex = Specific marking of explosive protection

II = Equipment Group hazardous area characteristics

2 = Equipment Category

G = Type of explosive atmosphere (gases, vapors, or mists)

EEx0.24mJ = The Vector Solo 79900 Applicators are suitable for use in manual spraying installations complying with EN 50 050 as they are a Type A class with a discharge energy limit of 0.24mJ.

Label 79846-00

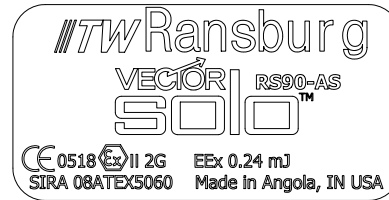

Label 79852-00

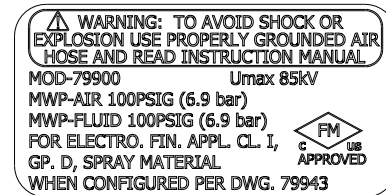

FM Configuration

This applicator is FM approved when configured to drawing 79943 shown on pages 7 and 8.

VECTOR SOLO RS90-AS SOLVENT BASED

79900 - ABCDE

BASE OPTION
MODEL NO. DESIGNATIONS
(ORDERING INFORMATION ONLY)

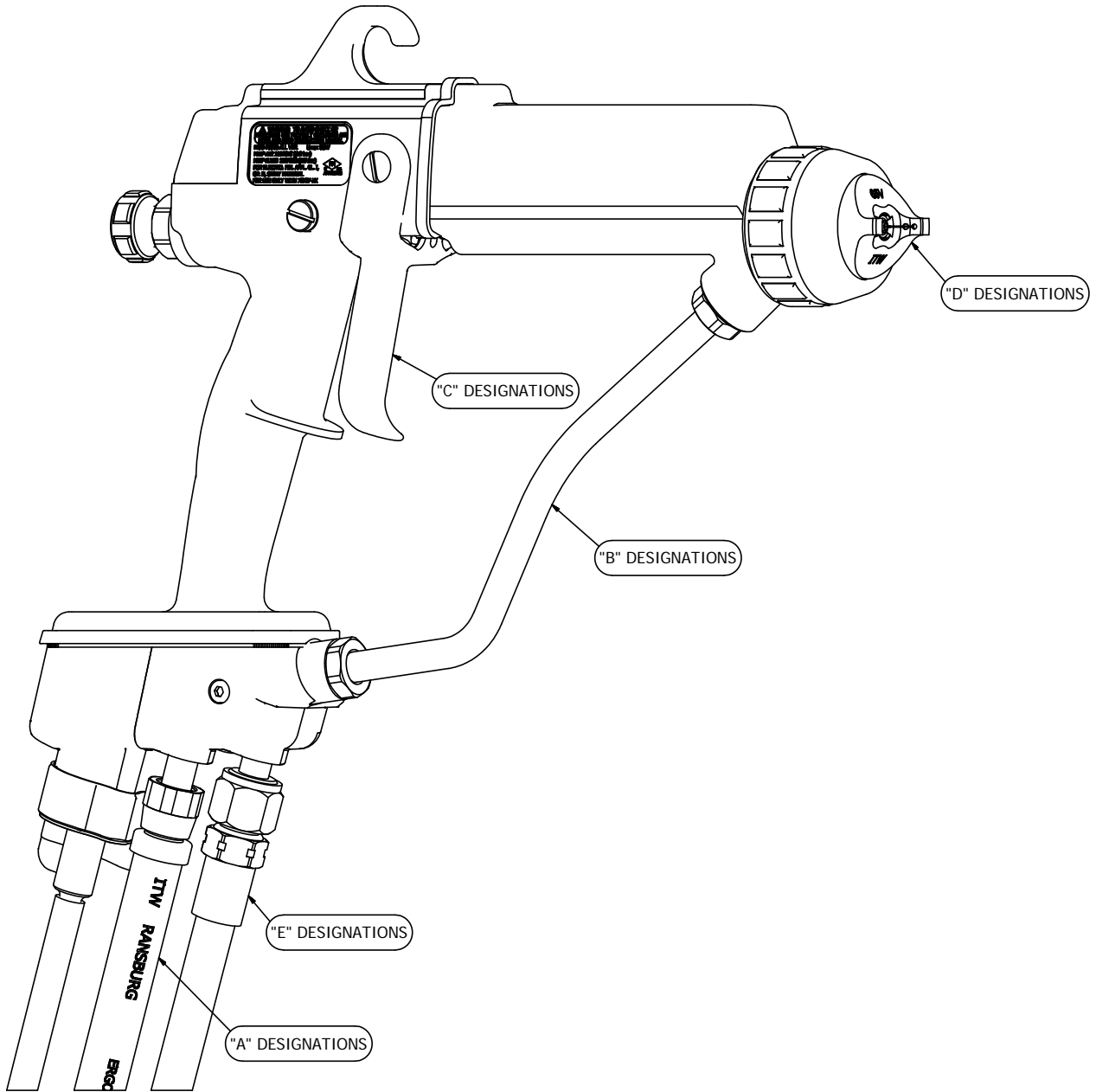

CONFIGURATION DWG. 79943 REV C

VECTOR SOLO RS90-AS SOLVENT BASED

79900 - ABCDE

BASE OPTION
MODEL NO. DESIGNATIONS

(ORDERING INFORMATION ONLY)

OPTION "A" DESIGNATIONS

AIR HOSE TYPE AND LENGTH

- 1 FOR STANDARD AIR HOSE ASSEMBLY, 10 METER (33')-PART NUMBER: 79727-10
- 2 FOR STANDARD AIR HOSE ASSEMBLY, 15 METER (49')-PART NUMBER: 79727-15
- 3 FOR STANDARD AIR HOSE ASSEMBLY, 20 METER (66')-PART NUMBER: 79727-20
- 4 FOR STANDARD AIR HOSE ASSEMBLY, 30 METER (99')-PART NUMBER: 79727-30
- 5 FOR QD AIR HOSE ASSEMBLY, 10 METER (33')-PART NUMBER: 79727-11
- 6 FOR QD AIR HOSE ASSEMBLY, 15 METER (49')-PART NUMBER: 79727-16
- 7 FOR QD AIR HOSE ASSEMBLY, 20 METER (66')-PART NUMBER: 79727-21
- 8 FOR QD AIR HOSE ASSEMBLY, 30 METER (99')-PART NUMBER: 79727-31

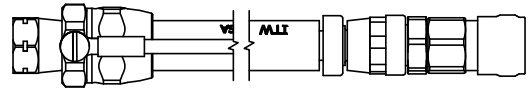
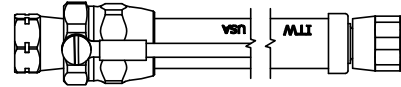

OPTION "B" DESIGNATIONS

FLUID INLET TUBE

- 1 FOR STANDARD FLUID TUBE, .093" ID-PART NUMBER: 79878-01
- 2 FOR COILED FLUID TUBE, .125" ID-PART NUMBER: 79871-00
- 3 FOR FLUID TUBE, 1/8" ID-PART NUMBER: 79878-02
- 4 FOR FLUID TUBE, 1/4" ID-PART NUMBER: 79878-03

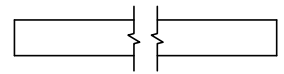
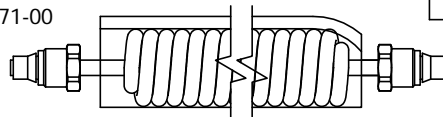

OPTION "C" DESIGNATIONS

TRIGGER TYPE

- 2 FOR TWO FINGER TRIGGER-PART NUMBER: 79787-00

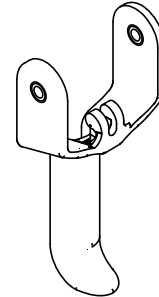

OPTION "D" DESIGNATIONS

SPRAY TECHNOLOGY

- 0 FOR STANDARD SPRAY, 65V CAP, #44 NOZZLE-PART NUMBER: 79374-65 & 79377-44
- 1 FOR STANDARD SPRAY, 65V CAP, #45 NOZZLE-PART NUMBER: 79374-65 & 79377-45
- 2 FOR TRANSTECH SPRAY, 122V CAP, #245 NOZZLE-PART NUMBER: 79374-122 & 79552-245
- 3 FOR ROUND SPRAY-PART NUMBER: 79662-00 & 79559-00
- 4 FOR STANDARD SPRAY, 65V CAP, #48 NOZZLE-PART NUMBER: 79374-65 & 79377-48

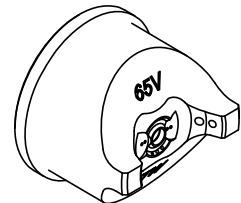
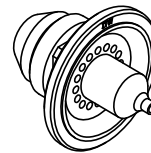

APPROVED SPARE FLUID NOZZLES LIST

- 79377-46 (1.06mm ID, STD. WEAR), 79377-47 (.71mm ID, STD. WEAR),
- 79377-48 (1.19mm ID, STD. WEAR), 79377-144 (1.40mm ID, HIGH WEAR),
- 79377-145 (1.78mm ID, HIGH WEAR), 79377-146 (1.06mm ID, HIGH WEAR),
- 79377-147 (.71mm ID, HIGH WEAR), 79552-244 (1.40mm ID, STD. WEAR),
- 79552-344 (1.40mm ID, HIGH WEAR), 79552-345 (1.78mm ID, HIGH WEAR)

OPTION "E" DESIGNATIONS

FLUID HOSE LENGTH

- 0 FOR NO FLUID HOSE
- 1 FOR FLUID HOSE, 10m-PART NUMBER: 79548-10
- 2 FOR FLUID HOSE, 15m-PART NUMBER: 79548-15
- 3 FOR FLUID HOSE, 20m-PART NUMBER: 79548-20
- 4 FOR FLUID HOSE, 30m-PART NUMBER: 79548-31

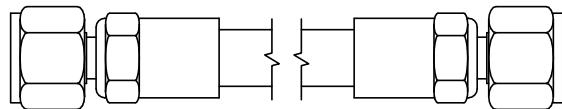

CONFIGURATION DWG. 79943 REV C

INTRODUCTION

GENERAL DESCRIPTION

The **Vector Solo™** is an air atomizing applicator powered only by a pressurized air source. Pressurized air creates rotation of a turbine generator that powers a cascade. The cascade generates a high voltage DC charge to the electrode creating an electrostatic field between the atomizer and the target.

A regulated pressure fluid system delivers coating material to the atomizer. At the time of triggering the applicator, fan and atomization air is introduced, which atomizes the coating material into a spray mist. The atomized spray particles under the influence of the electrostatic field become electrically charged. The charged particles are attracted to, and deposited on, the target object. The forces between the charged particles and the grounded target are sufficient to turn most normal overspray around and deposit it on the back surface of the target. Therefore, a high percentage of the coating is deposited on the target.

One of the many features of the Vector Solo applicator system is that the electrical energy, which is available from the resistive charging electrode, is limited to the optimum level of safety and efficiency. The system is incapable of releasing sufficient electrical or thermal energy during normal operating conditions to cause ignition of specific hazardous materials in their most easily ignited concentrations in air.

As the applicator electrode approaches ground, applicator circuitry causes the high voltage to approach zero while the current approaches its maximum value.

NOTES

79900 VECTOR SOLO SOLVENTBORNE SPECIFICATIONS

Environmental/Physical

Applicator Length:	320mm (12.6-inches)
Weight:	880 grams (31.0 oz.)
Hose 79727-XX Lengths (Std):	10m, 15m, 20m, and 30m
Atomizer Nozzle Assembly (Std):	79374-65, 79377-44 (1.4mm)

Electrical

Operating Voltage:	85kV DC (-) maximum
Current Output:	130 microamperes maximum
Paint Resistance:*	.1 MΩ to ∞ *(Use Model No. 76652, Test Equipment)
Part Sprayability:	Determine sprayability of part to be coated using 76652, Test Equipment

(See current "Paint, HV & SCI Test Equipment" service manual.)

Mechanical

Fluid Flow Capacity:	1000 ml/minute**
Wetted Parts:	Stainless, polyethylene, nylon, acetal polymer
Operating Pressure (Air Spray)	
Fluid:	(0-6.9 bar) 0-100 psi
Air:	(0-6.9 bar) 0-100 psi
Ambient Temp.:	40°C to 0°C (104°F to 32°F)
Consumption:	470 SLPM (16.6 SCFM) @ 2.8 bar (40 psig) @ Handle Inlet
Sound Level:	92dB (A) @ 2.8 bar (40 psig) Inlet, 1m from applicator
Vibration Level:	0.065 m/s ² @ 2.8 bar (40 psig) @ Handle Inlet

** This reflects the maximum fluid volume the applicator can deliver. The maximum spray volume that can be effectively atomized depends on fluid rheology, spray technology, and finish quality required.

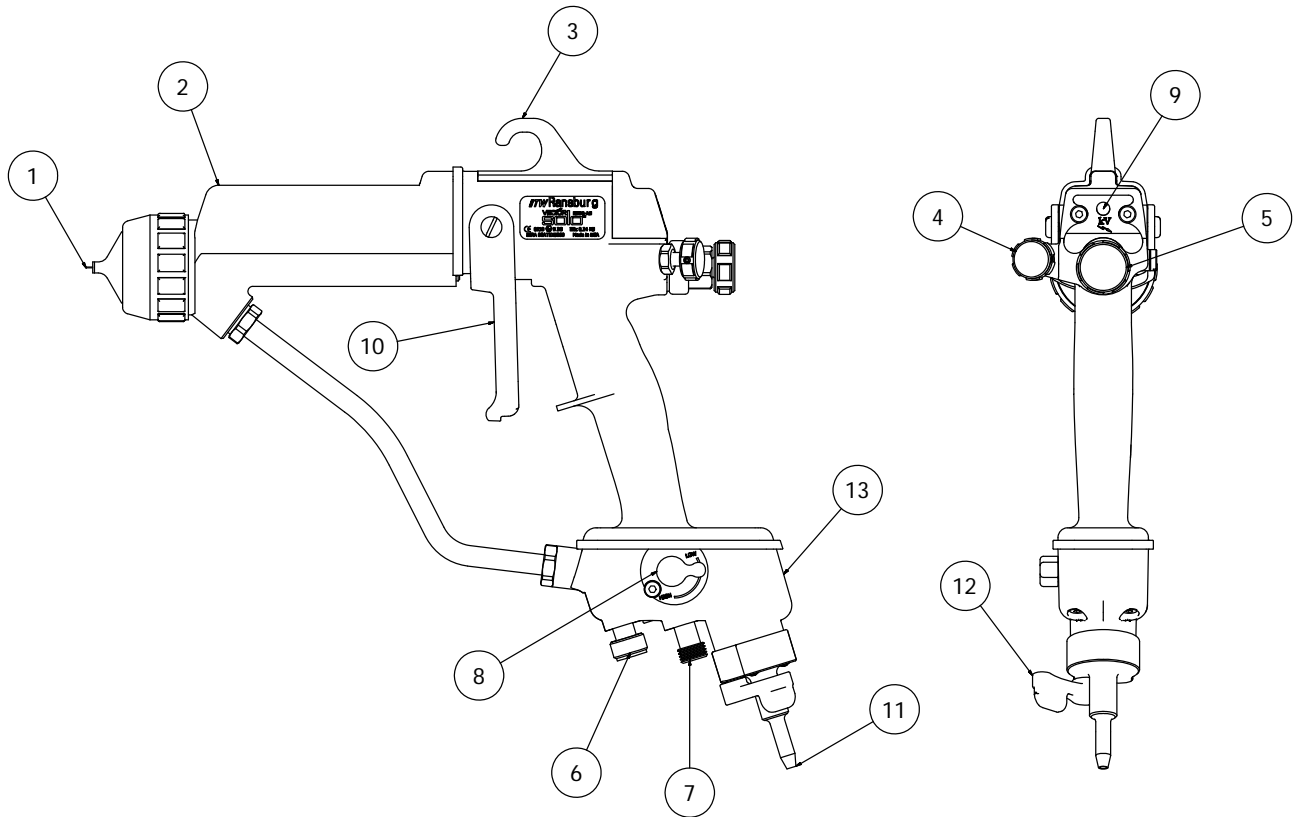

Figure 1: Vector Solo Solventborne Electrostatic Spray Applicator

VECTOR SOLO SOLVENTBORNE ELECTROSTATIC SPRAY APPLICATOR			
No.	Description	No.	Description
1	Needle/Electrode	8	kV Setpoint Switch
2	Barrel	9	Voltage On/Off Indicator Light
3	Replaceable Hook	10	Trigger
4	Fan Air Adjustment	11	Turbine Air Exhaust
5	Fluid Needle Travel Adjustment	12	Voltage On/Off Lever
6	Fluid Hose Connection	13	Power Module
7	Air Inlet Connection		

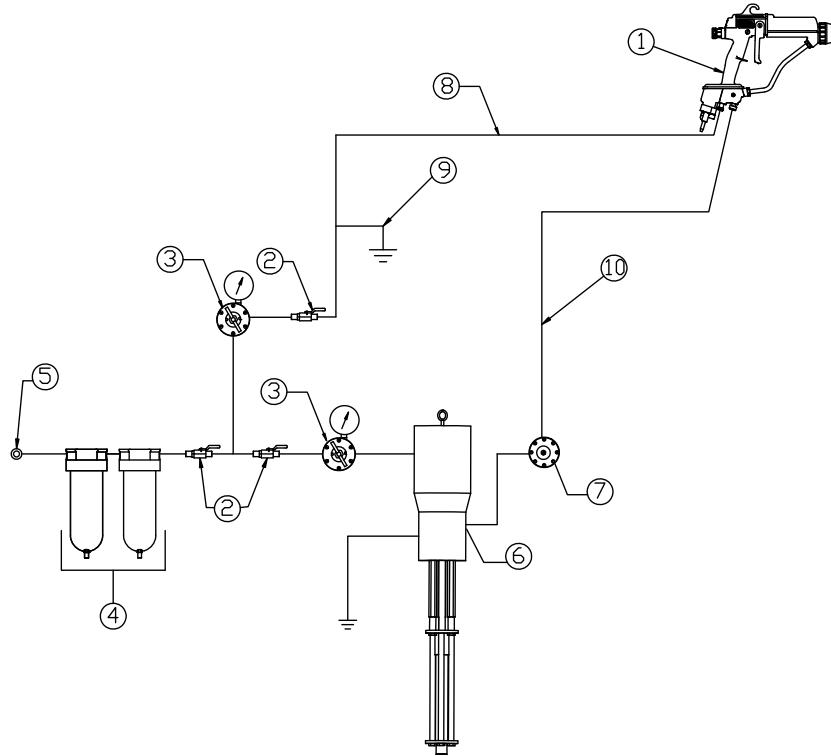

Figure 2: Vector Solo Typical Solventborne Installation

VECTOR SOLO TYPICAL SOLVENTBORNE INSTALLATION			
No.	Description	No.	Description
1	Vector Solo	7	Fluid Regulator
2	Ball Valve	8	Air Hose (79727-XX)
3	Air Regulator W/Pressure Gauge	9	Air Hose Ground Wire
4	Air / Water Separator	10	Fluid Line
5	Main Air Supply Line		
6	Fluid Supply (Grounded)		

INSTALLATION

Air Hose

WARNING

- ▶ For proper safe function of the applicator, the 79727-XX Air Hose must be used (either standard or quick disconnect style).

Fluid Hose Recommendation

ITW Ransburg recommends using a 79548 fluid hose assembly. This assembly is made to specifically fit the fluid fitting size engineered into the applicator. This hose is available from your authorized ITW Ransburg distributor. Available hose lengths are listed in "Accessories" in the "Parts Identification" section of this manual.

CAUTION

- ▶ Any user installed fluid hose used must be rated for 100 psig (6.9 bar) working pressure minimum.

Filters

1. Install an air filter assembly on the outlet of the main air regulator. The filter should be 5 micron with a maximum working pressure of at least 100 psig (6.9 bar). For Class 3 air quality, which is a 5 micron size and has a dew point of -4F (-20C), the relative humidity (RH) of the air should be 5%.

Screw the fitting into the filter inlet. The filter **MUST** be installed with the arrow pointing in the direction of flow. (Refer to the appropriate Filter Assembly manual for Installation Instructions.)

2. ITW Ransburg recommends that a fluid filter be installed at the output of the fluid supply (pressure pot, pump, circulating system, etc.). It is the end user's responsibility to install the proper filter that meets their system's requirements.

79900 SOLO SOLVENTBORNE INSTALLATION

WARNING

- ▶ The user **MUST** read and be familiar with the "Safety" section of this manual.
- ▶ This hand held device is intended to be used by trained personnel **ONLY**.
- ▶ This manual **MUST** be read and thoroughly understood by **ALL** personnel who operate, clean, or maintain this equipment! Special care should be taken to ensure that the warnings and requirements for operating and servicing safely are followed. The user should be aware of and adhere to **ALL** local building and fire codes and ordinances as well as NFPA, OSHA, and all related country safety codes prior to installing, operating, and/or servicing this equipment.
- ▶ Personnel **MUST** be **GROUND**ED to prevent a shock or spark during electrostatic operation.
- ▶ Install and route the hoses so they are **NOT** exposed to temperatures in excess of 120° F and so that all hose bends are **NO LESS** than a 6-inch (15cm) radius. Failure to comply with these parameters could cause equipment malfunction that might create **HAZARDOUS CONDITIONS!**

Interlocks Required

Interlock the solvent supply with the main supply air to the applicator. When solvent is On, main supply air to the applicator is Off. Interlocks are user supplied.

! WARNING

► The solvent supply must be interlocked with applicator supply air.

INSTALLATION

1. Ensure there is a true earth ground connection available.

! WARNING

► Both the fluid source and the air hose ground must be connected to true earth ground.

2. Connect the fluid source to true earth ground.
3. Ensure electrostatic On/Off lever is in the Off position.

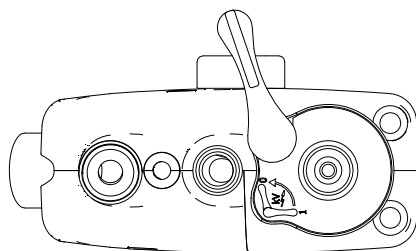

Figure 3: Voltage Off Lever Position (Bottom View)

4. Connect the air hose ground wire to true earth ground.
5. Connect the air hose to the applicator, **thread is left hand pitch**, counter-clockwise to tighten.

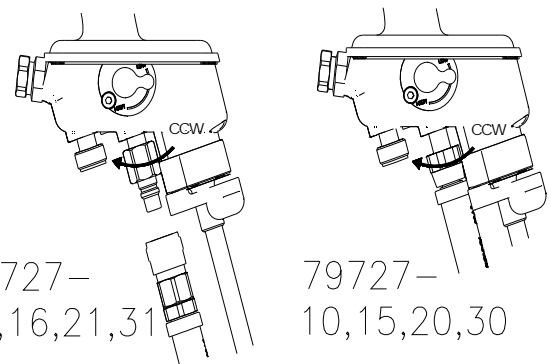

Figure 4: Air Hose Connection

6. Connect fluid hose from grounded fluid source.

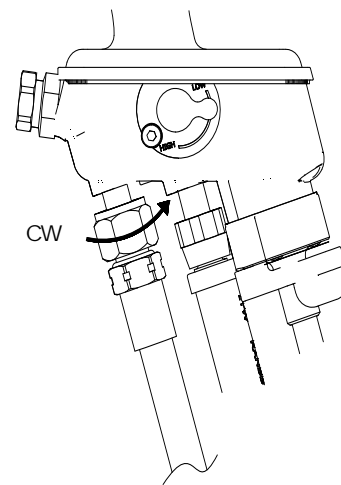

Figure 5: Fluid Hose Connection

7. Trigger the applicator with fluid off. Look for air leaks in any connections.
8. Activate fluid, check for leaks with solvent. Flush if required. (See "Operation" section for sequence.)

To aid with process consistency, the following "Maps - Manual Application Process Sheet" is included in the manual. It may be used for initial setup and commissioning of the applicator or for documentary regular process checks. Use of Installation and Setup Kit 76591-00 with Test and Maintenance Kit 79870-00 may be used to obtain the process information from the Maps sheet.

MAPS

MANUAL APPLICATION PROCESS SHEET

Customer Data			
Customer:		Date:	
Location:		ITW Representative:	
Cust. Contact:		Product Desc:	
Cust. Phone #:		Product Substrate:	
Distributor:		Material Use:	Prime Base Clear
Dist. Contact:		Material Base:	Water Solvent
Dist. Phone:		Material Compound:	1K 2K 3K

Atomizer / Material Data						
ITEM	Current	Trial 1	Trial 2	Trial 3	Trial 4	Final
Gun Type						
Gun Part Number						
Gun Serial Number						
Air Cap						
Fluid Nozzle						
Air Line ID						
Air Line Length						
Fluid Line ID						
Fluid Line Length						
Material Viscosity						
Material % Solids						
Material Resistivity						

Process Data						
Air Supply Pressure						
Air Pressure @ Gun Inlet						
Test Cap Gauge: Fan						
Test Cap Gauge: Atom						
Pattern Size (@ 10 in)						
Fluid Flow Rate (cc/min)						
Approx. spray time per part						
Approx. flow per part (cc)	0	0	0	0	0	0
Conveyor Speed (ft/min)						
Approx. Mil Wet						
Approx Mil Dry						
Part - Ground Continuity						

Comments

NOTES

OPERATION

1. Ensure the On/Off switch is in the desired position for voltage.

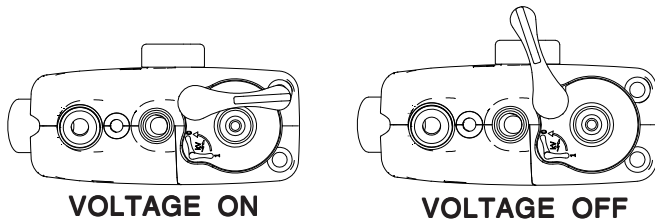

Figure 6: Voltage On/Off Position

2. Ensure the voltage high/low switch is in the desired position.

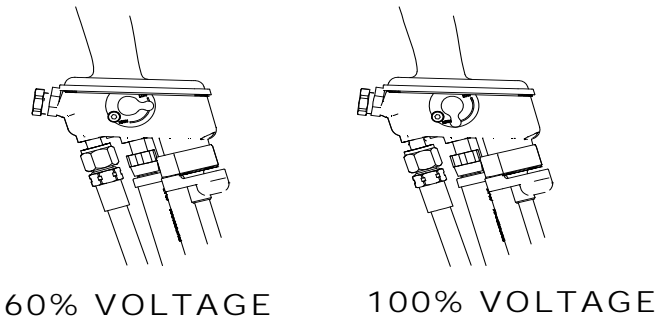

Figure 7: High/Low Voltage Selection

3. Open the fluid supply - 6.96 bar (100 psig) maximum working pressure.

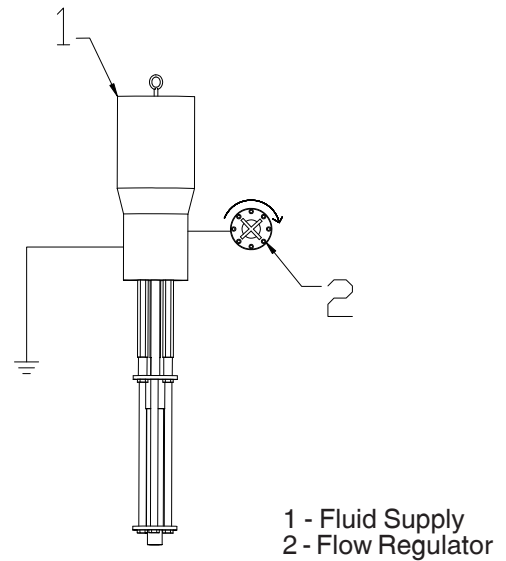

Figure 8: Fluid Supply Pressure Adjustment

4. Increase air pressure to the applicator depending upon atomization requirements. Minimum pressure is 2.75 bar at the handle (40 psig). Use either gauge from Maintenance and Test Kit or use Table I to use a gauge reading at the wall regulator adjusted for the pressure drop in the air hose.

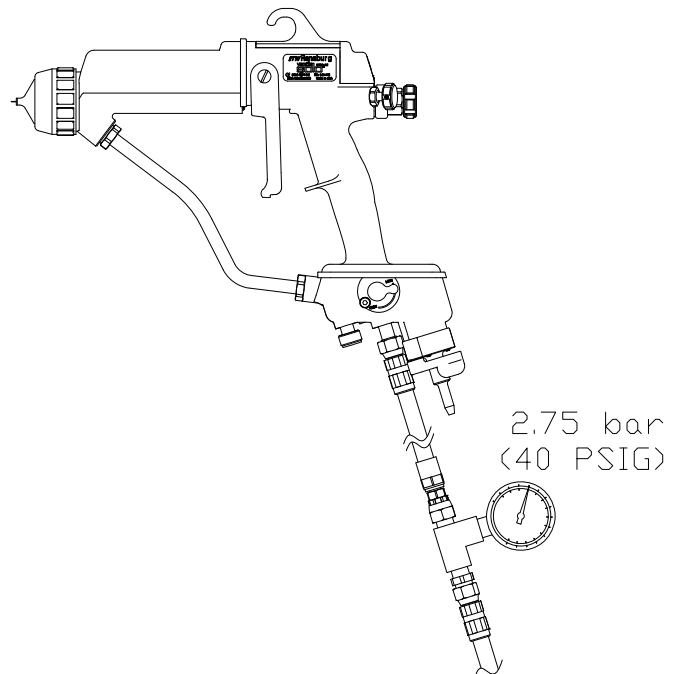

Figure 9: Air Pressure at Regulator

Table I - Pressure at Regulator	
79729 Hose Length	Pressure At Wall Regulator Gauge
30m	5.9 bar (85 psig)
20m	4.8 bar (70 psig)
15m	4.5 bar (65 psig)
10m	4.1 bar (60 psig)

5. Adjust fan pattern size. Counter-clockwise makes the fan pattern longer; clockwise makes the pattern shorter. Full clockwise creates a small circular pattern.

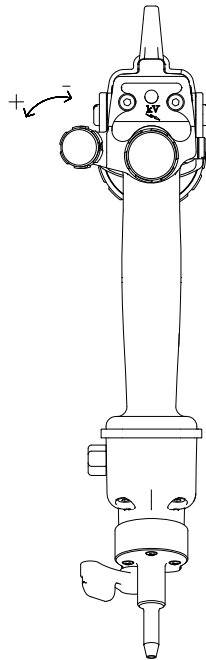

Figure 10: Fan Pattern Size Adjustment

6. To change the spray pattern axis of fan atomizers from horizontal to vertical, loosen the air nozzle retaining ring, rotate the air cap clockwise to the desired position, and tighten the ring.

7. Use the "Fluid Nozzle Selection Chart and Air Cap/Fluid Nozzle Performance Chart" in the "Installation" section to select the proper air cap and fluid nozzle for the applications.

8. The applicator is shipped standard with a plug in the atomization air port. If lower atomization air pressures are desired, a compensation valve is included with each applicator and can be used instead of the plug. The compensation valve (included separate with applicator) reduces the atomization air pressure approximately 0.2bar (3 psig) per clockwise turn from the wide open position. To determine what pressure the applicator is set at, use the Air Cap Test Kit in the "Parts Identification" - Accessories" section.

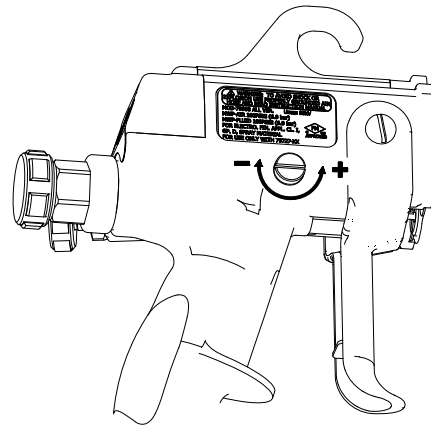

Figure 11: Compensation Valve - Full Open Position

FLUSHING / COLOR CHANGE PROCEDURE

1. Turn electrostatic lever to Off position.

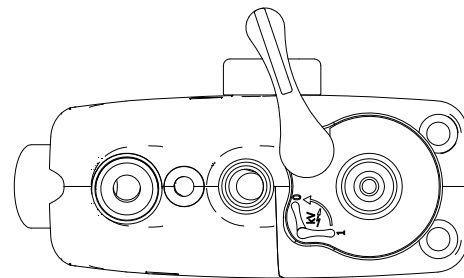
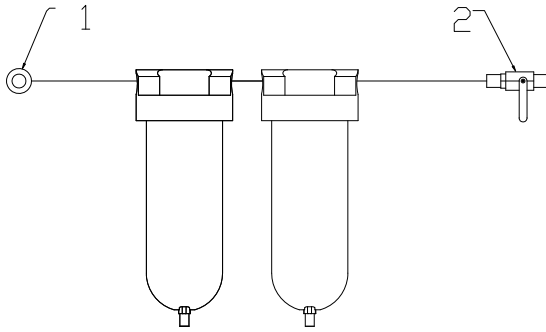

Figure 12: Electrostatics Lever Off Position

2. Turn off supply air.



1 - Main Air Supply
2 - Closed Ball Valve

Figure 13: Applicator Supply Air - Off

! WARNING

► Supply air to the applicator must be interlocked with the solvent supply. Supply air must be off whenever solvent supply is on.

3. Discharge fluid into appropriate grounded metallic container.

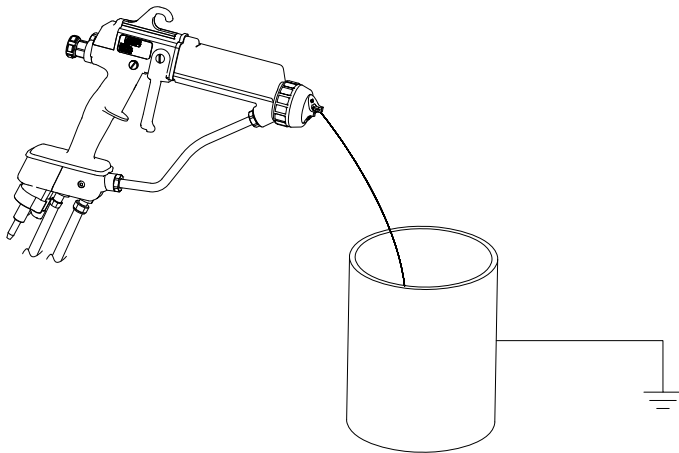

Figure 14: Applicator Flush Out

4. Load next color or remove applicator from installation as required.

NOTES

FLUID NOZZLE / AIR CAP

The fluid nozzle and air cap must be selected according to the application. The following charts show the nozzles and air caps available for the Vector Solo.

FLUID NOZZLE SELECTION CHART		
Fluid Nozzle Part #	Orifice ID	Nozzle Material
79377-44	1.4mm (.055 inch)	Standard Wear
79377-144	1.4mm (.055 inch)	Extended Wear
79377-45	1.8mm (.070 inch)	Standard Wear
79377-145	1.8mm (.070 inch)	Extended Wear
79377-46	1.0mm (.042 inch)	Standard Wear
79377-146	1.0mm (.042 inch)	Extended Wear
79377-47	.7mm (.028 inch)	Standard Wear
79377-147	.7mm (.028 inch)	Extended Wear
79377-48	1.2mm (.047 inch)	Standard Wear
79377-148	1.2mm (.047 inch)	Extended Wear

FLUID NOZZLE SELECTION TRANS-TECH. CHART		
Fluid Nozzle Part #	Orifice ID	Nozzle Material
79552-244	1.4mm (.055 inch)	Standard Wear
79552-344	1.4mm (.055 inch)	Extended Wear
79552-245	1.8mm (.070 inch)	Standard Wear
79552-345	1.8mm (.070 inch)	Extended Wear
79552-246	1.0mm (.042 inch)	Standard Wear
79552-346	1.0mm (.024 inch)	Extended Wear
79552-247	.7mm (.028 inch)	Standard Wear
79552-347	.7mm (.028 inch)	Extended Wear
79552-248	1.2mm (.047 inch)	Standard Wear
79552-348	1.2mm (.047 inch)	Extended Wear

AIR CAP / FLUID NOZZLE PERFORMANCE CHART							
Fluid Nozzle Part #	Orifice ID (in/mm)	Fluid Delivery* (ml/min)	Spray Type	Air Cap	Pattern Size** (inches)	Pressure Reducer	Applicators
79377-44	.055/1.4	300	Air Spray	79374-65	15±1/2	Yellow	Solo
79377-44	.055/1.4	300	Air Spray	79374-98	17±1/2	Yellow	
79552-244	.055/1.4	300	LVMP	79374-122	11.5±1/2	Green	

* Material: Lacquer, 18 Sec. No. 4 Ford Cup @ 72°F. Results are material dependent.

** Patterns at 8-inch target distance.

MAINTENANCE

SUITABLE SOLVENTS FOR CLEANING VECTOR SOLO APPLICATORS

When cleaning the applicator, a suitable solvent for cleaning depends on the part(s) of the applicator to be cleaned and the material that needs to be removed. ITW Ransburg recommends that all exterior cleaning be done with non-polar solvents to prevent a conductive residue on critical components. We also understand that some of these solvents do not always meet the cleaning needs of some materials. If conductive polar solvents are used to clean the applicator components, all residue must be removed using a non-conductive non-polar solvent (i.e. high flash Naphtha). If there are any questions as to what solvents are best for cleaning, contact your local ITW Ransburg distributor and/or your paint supplier.

The Vector applicator, air hoses, and fluid hose assemblies should not be submerged or soaked in solvent. However, the outer surfaces of these items can be wiped with a suitable cleaning solvent. The items that cannot be soaked are noted throughout this manual. All electrical components **cannot** be cleaned or soaked in any solvents.

NOTE

- ▶ Use a non-polar solvent wipe as the final cleaning sequence for cleaning all parts.

⚠ WARNING

- ▶ The user **MUST** read and be familiar with the safety instructions in this manual.
- ▶ If compressed air is used in cleaning, **REMEMBER** that high pressure air can be dangerous and should **NEVER** be used against the body. It can blind, deafen, and may even penetrate the skin. If used for cleaning equipment, the user should wear safety glasses.
- ▶ **ALWAYS** turn the on/off lever on the power module off prior to cleaning and servicing the equipment.
- ▶ Be **SURE** the power is **Off** and the system is grounded before using solvent to clean **ANY** equipment.
- ▶ **DO NOT** operate a faulty applicator!
- ▶ When using cleaning solvent, standard health and safety precautions should apply.
- ▶ Any solvent used to clean the fluid passages must be discharged into a grounded container. Use of ungrounded or plastic containers may cause fire or explosion.
- ▶ Cleaning of the exterior surface of the applicator should be done with non-polar solvents. If cleaning requires the use of polar solvents, the applicator should be wiped down with non-polar solvent prior to going back into use. Using polar solvents will leave a semi-conductive film on the surface of the applicator that will effect efficiency of the applicator and cause damage to the components.

ROUTINE SCHEDULE

Follow these maintenance steps to extend the life of the applicator and ensure efficient operation:

Several Times Daily

- Inspect the air cap for paint accumulation. Clean as frequently as necessary with a soft bristled brush and a suitable solvent.

! CAUTION

► **NEVER** remove the fluid nozzle assembly while paint is in the applicator or paint may enter into the air passages. Clogged or restricted air passages will cause poor atomization and/or electrical shorting. Air passages that are clogged with conductive material can lead to excessive current output levels and consequent low operating voltage or long-term electrical damage.

The applicator barrel **MUST** be tilted front down to remove the fluid nozzle. Failure to do so may allow paint to enter the air passages, thereby reducing airflow and damaging the applicator barrel/cascade. Applicators may be flushed in lieu of tilting. However, they must be either flushed or tilted down during nozzle removal!

- Clean all insulating surfaces in the system. Remove paint accumulation from the exterior of the applicator with a solvent dampened cloth.

! CAUTION

► **NEVER** soak or submerge the electrical components of the applicator, i.e., barrel, power module, or handle. Damage and failure may occur.

Daily (or at start of each shift)

- Verify that ALL solvent safety containers are grounded!
- Check within 6m (20-ft.) of the point of operation (of the applicator) and remove or ground ALL loose or ungrounded objects.
- Inspect work holders for accumulated coating materials (and remove such accumulations).
- Check that atomizer assembly is clean and undamaged.

NOTE

- Standard electrode is "snap back" spray wire electrode.

- Straighten the applicator electrode if necessary.
- Clean the fluid filter, if used.

Electrical Output Test

1. Turn the paint and/or solvent supply OFF.

! WARNING

► Paint and/or solvent supply must be turned off during this test - risk of fire or explosion.

2. Flush the applicator (see "Flushing Procedure" in the "Operation" section).

3. Follow instructions for use of the 76634-00 meter.

4. Using the meter set to kV, measure the output voltage of the applicator. Voltage output reading is between 67 and 75kV.

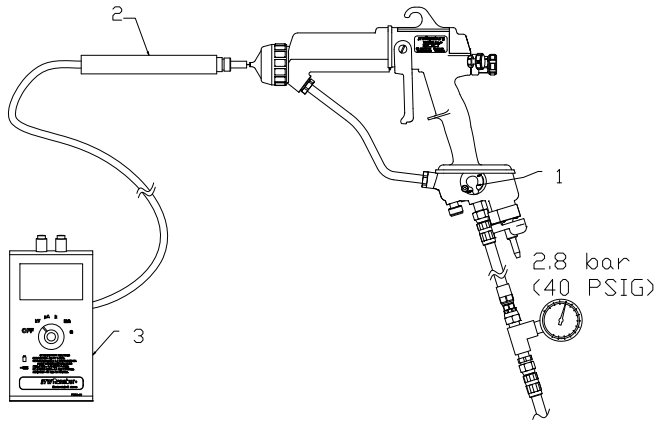

- 1 - Full Voltage Setting
- 2 - 76634-00 Meter
- 3 - 76667-00 kV Probe

Figure 15: kV Probe

5. See "Troubleshooting" in the "Maintenance" section for possible cause of poor performance.

NOTE

► There is a 10 giga ohm resistor in the probe that lowers the output voltage. The maximum kV rating is at no load. Paint overspray and other contaminants on the barrel will lower the kV probe reading.

APPLICATOR REPAIR

CAUTION

► **DO NOT** allow the fluid lines to stand empty without flushing first! This will cause dried paint flaking and clogging of the fluid lines, applicator passages, and/or nozzles.

All repairs should be made on a clean, flat surface. If a vise is used to hold parts during service or repair, **DO NOT** clamp onto plastic parts and always pad the vise jaws!

The following parts should be thoroughly packed with dielectric grease (LSCH0009-00) leaving **NO** air space or voids when assembling:

- All O-Rings (Teflon o-rings do not need lubrication)
- Needle Shaft Assembly
- Packing Tube
- Cascade and Barrel

Equipment Required

- Special Multi-Purpose Wrench (79854-00) *
- 4mm, 3mm, and 2.5mm Allen Wrenches *
- Screwdriver (blade)
- Jam Nut Removal Tool (79793-00) *
- Dielectric Grease (LSCH0009-00) *
- Sealant, Medium Strength (7969-10)
- Dowel, 6mm (1/4") diameter

Note: * Supplied with applicator

1. Remove applicator from the worksite after following the "Flush Procedure".

! WARNING

► Ensure all pressure has been bled from the fluid and air line prior to disconnection.

2. Remove fluid hose at base of applicator.

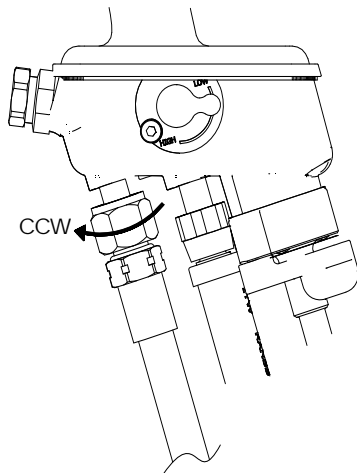

Figure 16: Counter-Clockwise to Remove Fluid Hose

3. Remove air hose at base of applicator.

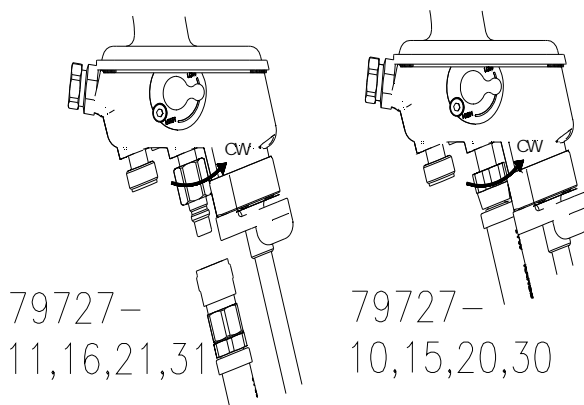

Figure 17: Clockwise to Remove Air Hose

AIR CAP

Removal

1. While holding the barrel with one hand, loosen the retaining nut using the other hand.
2. Unscrew the retaining nut completely and remove the air cap.

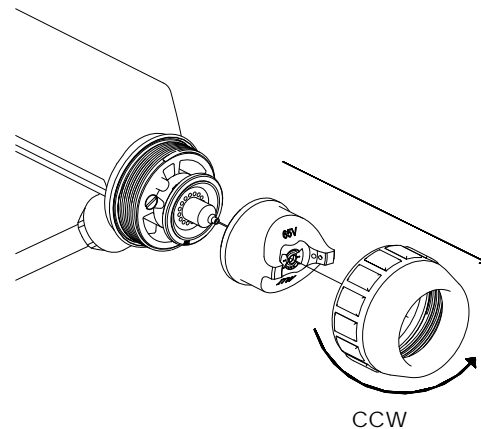

Figure 18: Air Cap Removal

Cleaning and Inspection

1. Use a suitable solvent to clean the air cap. (Refer to "Suitable Solvents for Cleaning Vector Solo Applicators" in the "Maintenance" section.)
2. Examine the air cap for damage to the air horns, face, and any air passages. If any of these areas are damaged or worn, the air cap should be replaced.

Reinstall

1. Check the fluid nozzle to ensure that it is tightly screwed into the barrel.
2. Place the air cap over the electrode wire of the needle/electrode and set it onto the fluid nozzle.
3. Place the retaining nut over the air cap and begin screwing it onto the barrel.
4. Before securing the retainer nut to the barrel, position the air cap for the desired spray pattern.

FLUID NOZZLE

(Refer to Figure 19)

Removal

1. Remove the air cap from the applicator (refer to "Air Cap - Removal" in the "Maintenance" section).
2. Tilt the applicator forward and pull the trigger to make sure that all fluid in the applicator is drained out.

CAUTION

► The applicator barrel **MUST** be tilted front down to remove the fluid nozzle. Failure to do so may allow paint to enter the air passages, thereby reducing airflow and damaging the applicator barrel. Applicators may be flushed in lieu of tilting. However, they **MUST** be either flushed or tilted during nozzle removal!

3. While holding the applicator assembly with the trigger pulled back, remove the fluid nozzle with the open-end of the special multi-purpose wrench.

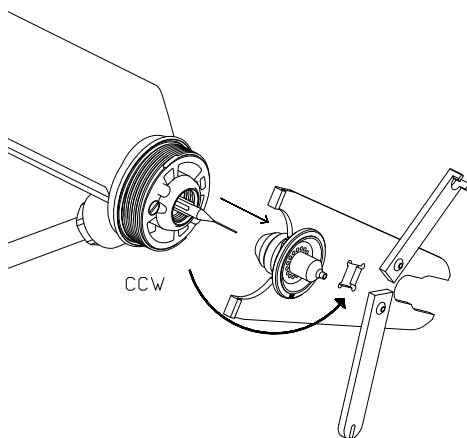

Figure 19: Fluid Nozzle Removal

NOTE

- To keep the needle/electrode from unscrewing from the needle shaft, the applicator's trigger should be actuated to pull the needle/electrode away from the fluid nozzle.

Cleaning and Inspection

1. Use a suitable solvent to clean the fluid nozzle. (Refer to "Suitable Solvents for Cleaning Vector Solo Applicators" in the "Maintenance" section.)
2. Examine the fluid nozzle for damage to the air passages and the fluid nozzle tip. Also, examine the needle seat for damage or wear. If any damaged or any worn areas are found, the fluid nozzle must be replaced.

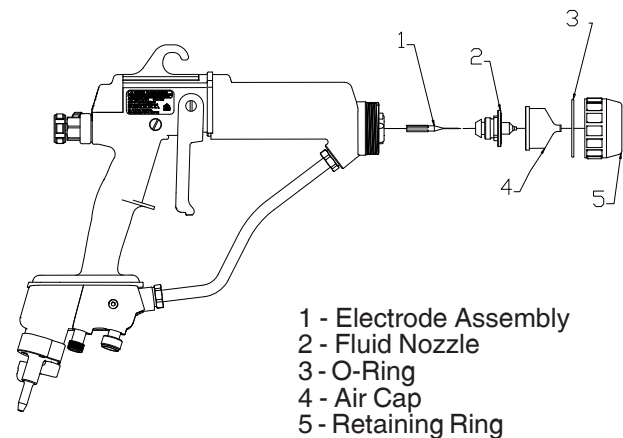

- 1 - Electrode Assembly
- 2 - Fluid Nozzle
- 3 - O-Ring
- 4 - Air Cap
- 5 - Retaining Ring

Figure 20: Applicator Front End Components

NOTE

- If the fluid nozzle is replaced, there is a good chance that the needle/electrode assembly will need to be replaced also. A worn needle/electrode assembly may not always seat well in a new fluid nozzle.

Reinstall

1. Check the electrode tightness on the needle shaft. If it is loose, tighten it (refer to "Needle/Electrode" in the "Maintenance" section).
2. With the applicator trigger actuated, place the fluid nozzle over the needle/electrode and screw it into the barrel by hand.
3. Tighten it using the Special Multi-Purpose Wrench 79854-00 with 3/8" square. Torque to 35-40 lbs•in (3.9-4.5 Nm). An alternate method (if no torque wrench is available) is to hand tighten, then tighten an additional 1/16 turn in the clockwise direction.

CW
35-40
LBS-IN
3.9-4.5 NM

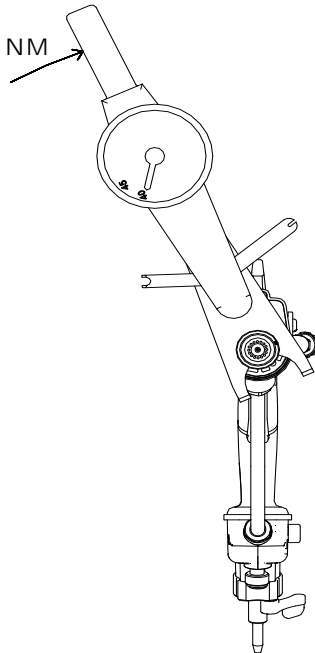

Figure 21: Reinstalling Fluid Nozzle

NOTE

- **TIGHTEN PROPERLY.**
Do not undertighten the fluid nozzle, as fluid can leak into the air passages. See torque range specified.
Do not over-tighten the fluid nozzle into the barrel. Doing so could damage or break the fluid nozzle or damage the thread of the barrel.

4. Install the air cap and retaining ring onto the applicator.

NEEDLE / ELECTRODE

Removal

1. Remove the air cap and fluid nozzle from the applicator assembly.
2. Secure the needle shaft at the rear of the barrel with the Special Wrench 79854-00 and unscrew the needle/electrode from the needle shaft.

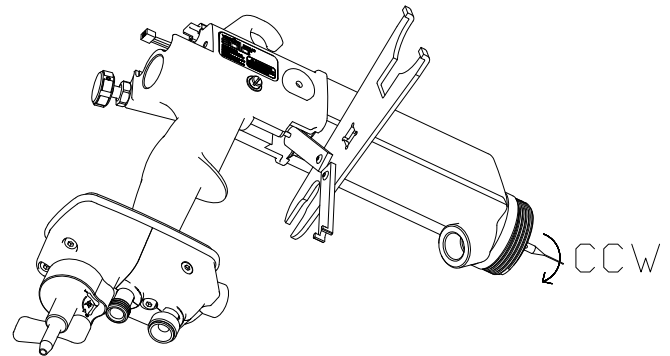

Figure 22: Electrode Removal

Cleaning and Inspection

1. Use a suitable solvent to clean the needle/electrode.
2. Examine the needle/electrode for damage or wear. Pay special attention to the area where the wire electrode extends from the main body. This is a sealing surface that seats inside the fluid nozzle. If there are signs of wear in this area, both the needle/electrode and fluid nozzle must be replaced.
3. An electrical check of the needle/electrode must be done prior to reinstalling it into the applicator assembly (refer to "Needle/Electrode Resistance Testing" in the "Maintenance" section).

Reinstall

1. Secure the needle shaft at the rear of the barrel and screw the needle/electrode into place by hand.
2. Reinstall the fluid nozzle and air cap onto the barrel.

NEEDLE / ELECTRODE RESISTANCE TESTING

The electrical resistance of the needle/electrode should be tested periodically (typically on a weekly basis) or any time it is removed from the applicator.

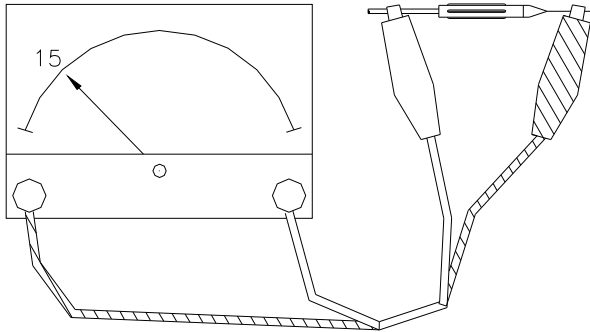

Figure 23: Testing Resistive Electrode

To Test

1. Install the needle/electrode onto the front end of an available needle shaft. Be sure that the needle/electrode is completely seated for proper contact between the metal shaft and the threaded insert of the needle/electrode.

2. Using a VOM meter that will read 15 megohms accurately, connect the first meter lead to the metal needle shaft and the second lead to the needle/electrode wire. The needle/electrode resistance should be 14.5 to 19 megohms (nominal 15 megohms at 9 volts or 12 to 17 megohms at 1000 volts). Needle/electrodes outside these ranges must be replaced.

BARREL REMOVAL

1. Remove air cap and fluid nozzle.
2. Remove two (2) screws with a 3mm Allen wrench that hold the rear cover. Remove rear cover and disconnect the connector.

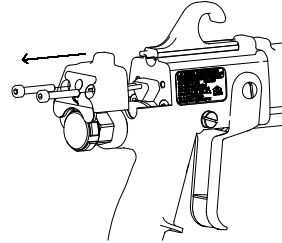

Figure 24: Rear Cover Removal

3. Remove the rear fluid adjustment bushing, and air valve and fluid needle return springs.

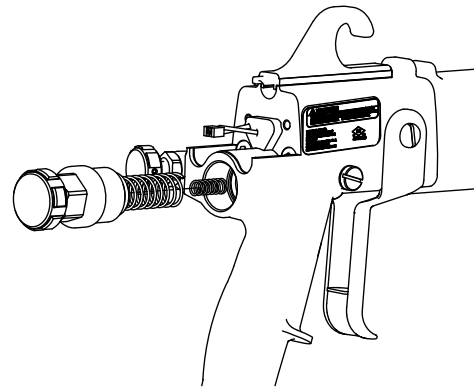

Figure 25: Fluid Adjust Bushing Removal

4. Remove the trigger and fluid line.

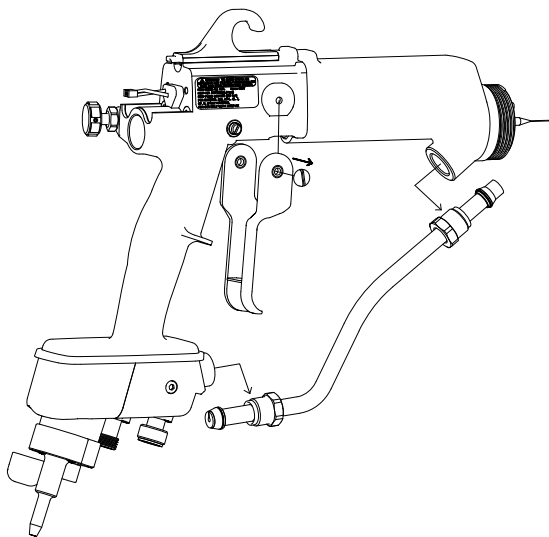

Figure 26: Fluid Line/Trigger Removal

5. Remove the two (2) jam nuts using the 79793-00 Removal Tool while holding the needle shaft with the 79854-00 Special Wrench.

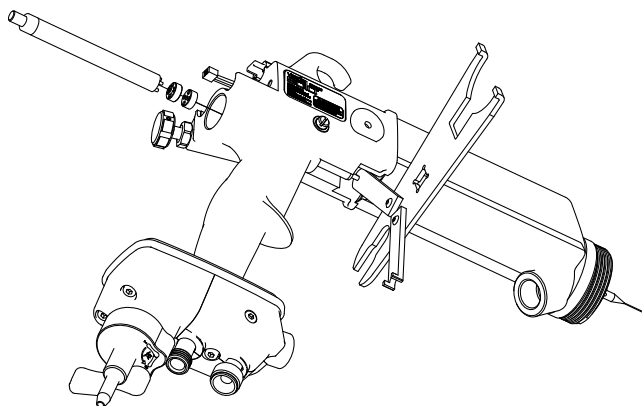

Figure 27: Jam Nut Removal

6. Remove three (3) 5mm screws using a 4mm Allen wrench. Remove the hook.

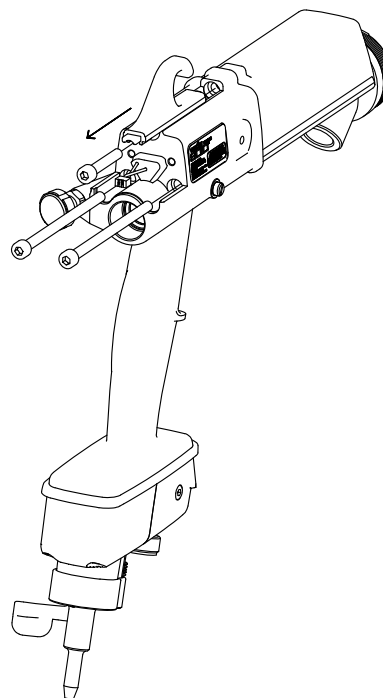

Figure 28: Barrel Screw Removal

7. Pull the barrel straight away from the handle.

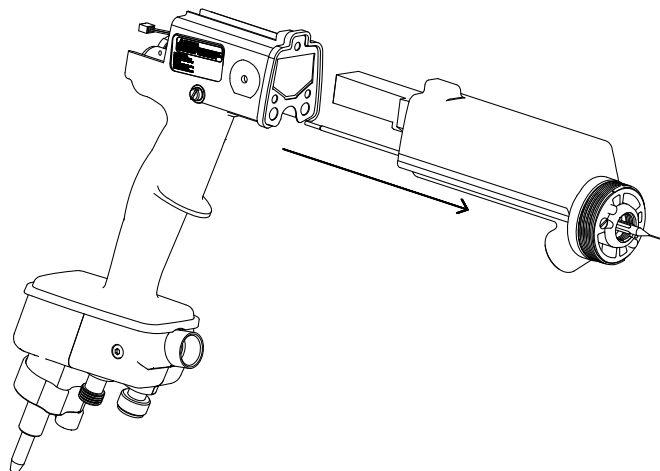

Figure 29: Barrel Removal

Remove Cascade

1. Pull the cascade out of the barrel.

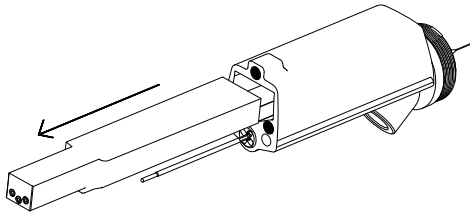

Figure 30: Cascade Removal

2. Wipe off excess dielectric lubricant.
3. Remove excess lubricant from inside barrel with a clean cloth or rag.

Replace Cascade

1. Dispense about 1/4 tube of LSCH0009-00 inside the barrel and on the sides of the cascade.

	CAUTION
<p>► Failure to use the LSCH0009-00 may shorten product life.</p>	

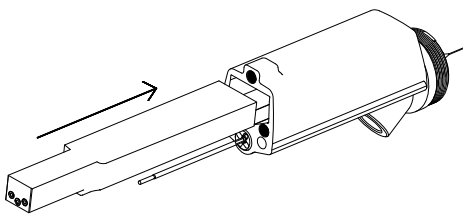

Figure 31: Cascade Replacement

2. Slide the cascade back into the barrel.

Reinstalling Barrel

1. Replace the hook. Install the barrel against the handle and hand tighten two (2) long 5mm screws, in an alternating sequence with the 4mm Allen wrench. Tighten the hook screw with the same 4mm wrench.

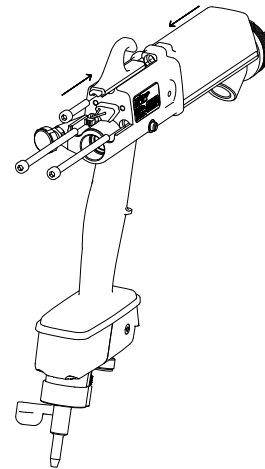
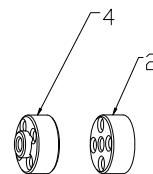
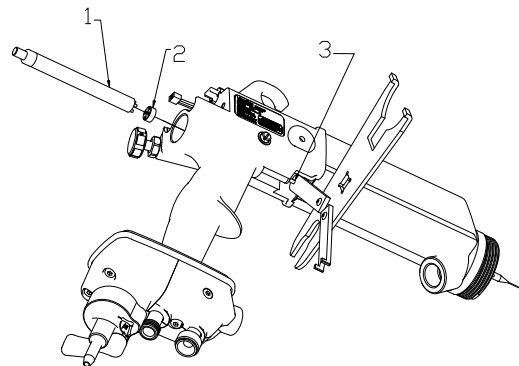

Figure 32: Installing Barrel to Handle

2. Install the first jam nut. Tighten to stop by hand while holding the needle shaft.



- 1 - 79793-00 Removal Tool
- 2 - 1st Jam Nut
- 3 - 79854 Special Wrench
- 4 - 2nd Jam Nut (Raised Center)

Figure 33: First Jam Nut Replacement

3. Tighten second jam nut with raised center facing out, while holding the needle shaft.

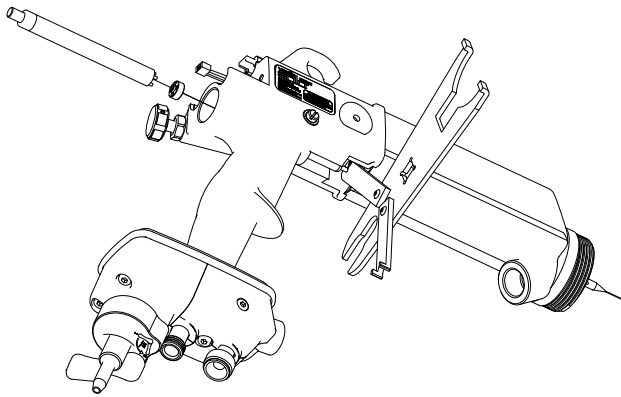

Figure 34: Second Jam Nut Replacement

5. Install trigger and fluid line and torque fluid tube fittings 40-45 lbs-in.

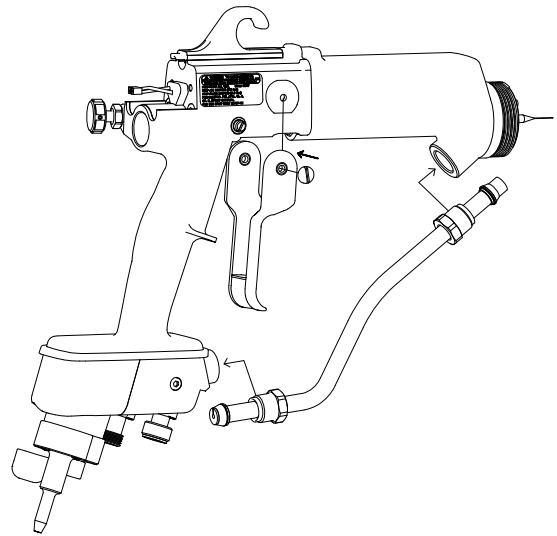
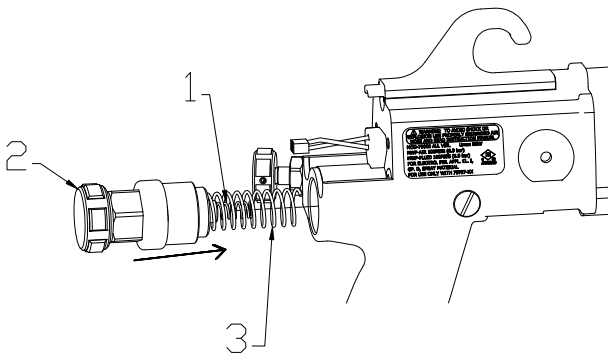

Figure 36: Fluid Line/Trigger Installation

4. Install the fluid adjustment assembly along with the air and fluid return springs.



- 1 - Fluid Return Spring
- 2 - Fluid Adjustment Valve
- 3 - Air Valve Return Spring

Figure 35: Spring and Fluid Adjust Valve Replacement

6. Reconnect the rear cover and install with two (2) 4mm screws.

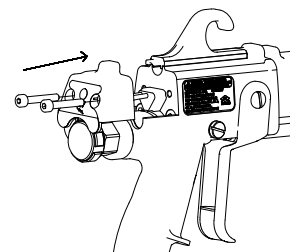
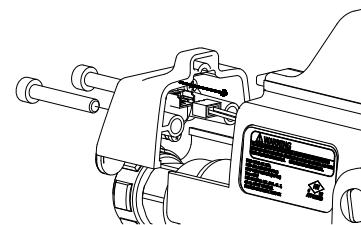

Figure 37: Rear Cover Replacement



NEEDLE SHAFT REMOVAL / REPLACEMENT

1. Remove barrel from the handle using previous steps.
2. Remove cascade.

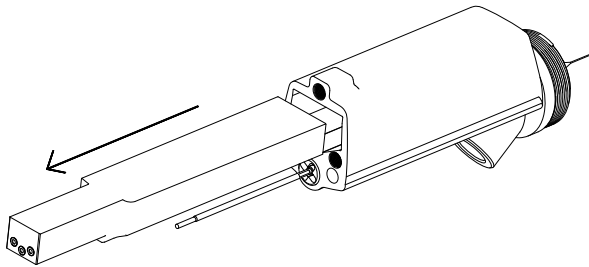

Figure 38: Cascade Removal

3. Remove rear nut using the 79854-00 Special Wrench.

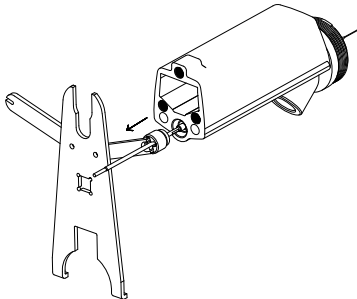

Figure 39: Needle Shaft Removal

4. Attach a jam nut to the assembly and pull straight out of the barrel.

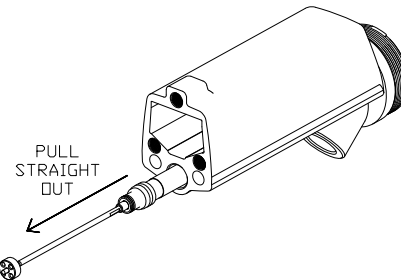

Figure 40: Needle Shaft Removal

5. Clean cavity with non-metallic brush and non-polar solvent.

6. Replace needle components as required. (See "79853-00 Needle Shaft Parts List" in the "Parts Identification" section for breakdown.)

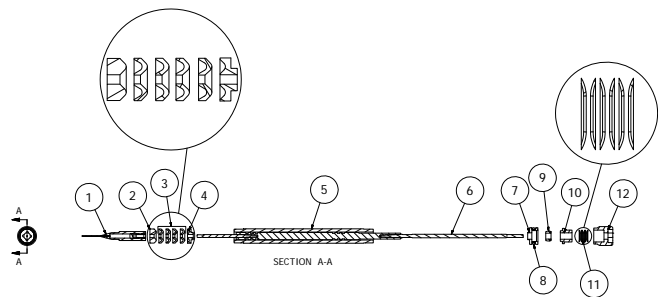

Figure 41: 79853-00 Needle Shaft with 2k Adjustable Packings

Needle Shaft Rebuild

1. Prior to installing the needle shaft, partially fill the internal bore of barrel with dielectric grease.
2. Screw the needle electrode onto the front of the needle shaft and hand tighten.
3. Fill the inner diameter of the packing tube with dielectric grease - LSCH0009-00.
4. Insert the needle shaft, rear section first, into the packing tube. Rotate the needle shaft while moving back and forth inside the packing tube until fully inserted.

5. With your finger, wipe the excess grease from both ends of the packing tube. Using the excess grease, apply a thin film to the outer surface of the packing tube and to the external o-ring on the cartridge seal.

NOTE

- Be generous with the dielectric grease when applying it to the packing tube and needle shaft. This helps to remove air voids from this chamber. **DO NOT** apply so much grease that it creates an air lock during assembly of the applicator.

6. Apply a light film of dielectric grease to the seal retainer o-ring and install it into the external groove.

Reinstall Needle Shaft / Barrel

1. Push needle shaft assembly straight into the barrel. Apply LSCH0009-00.

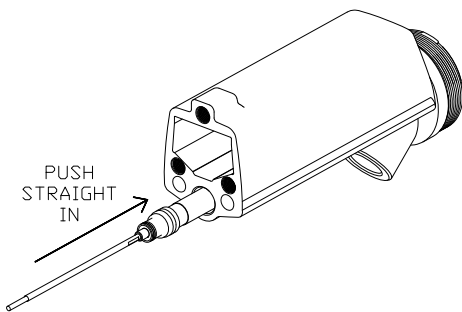

Figure 42: Needle Shaft Replacement

2. Tighten rear nut using Special Wrench 79854-00. Tighten until drag is felt on the shaft when it is pushed back and forth.

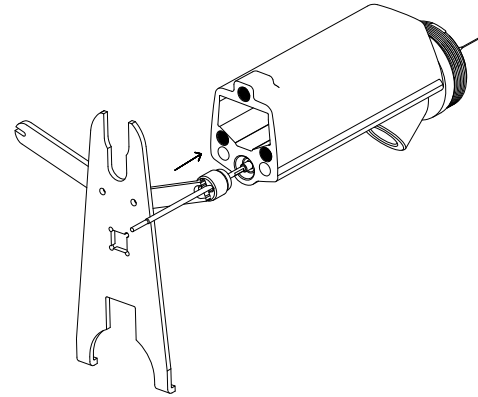

Figure 43: Adjustable Needle Shaft

3. Reinstall cascade.
4. Reinstall barrel to handle.

Power Module Removal

1. Remove the fluid line

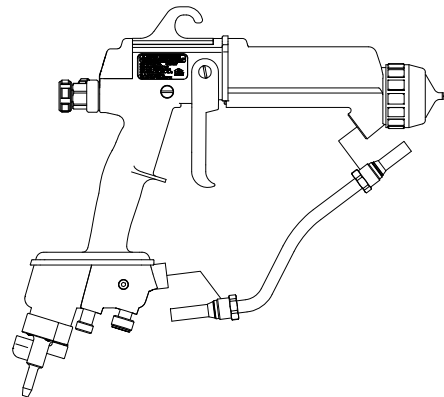

Figure 44: Fluid Line Removal

2. Remove three (3) bolts using a 3mm Allen wrench.

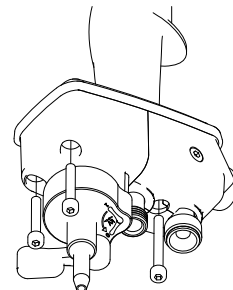

Figure 45: Power Module Removal

3. Pull the module straight off the handle.

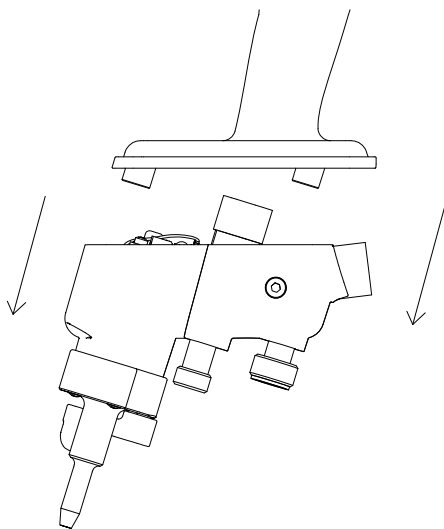

Figure 46: Power Module Removal

NOTE

► The power modules are not serviceable.

Handle Disassembly

1. Remove barrel.
2. Remove power module.
3. Push air valve out.

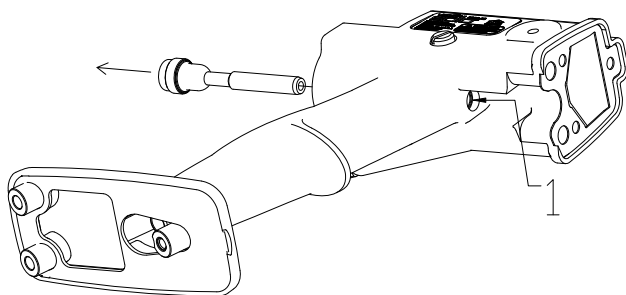

1 - Push Out From Here

Figure 47: Air Valve Removal

4. Remove the rear seal.

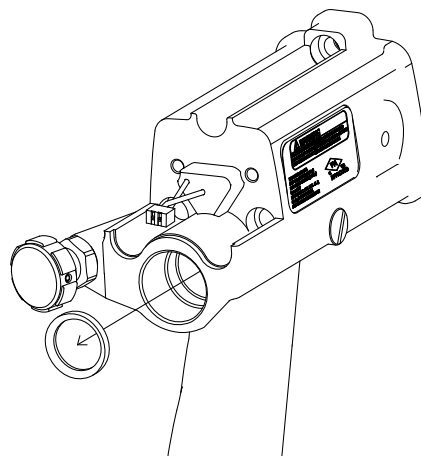
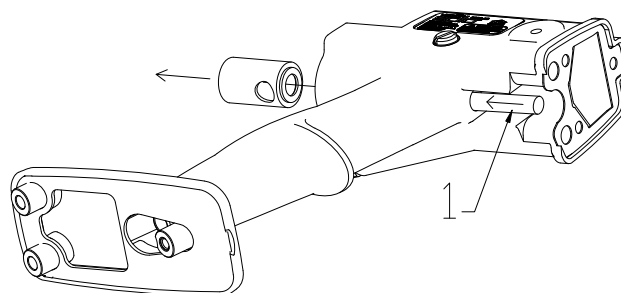

Figure 48: Rear Seal Removal

5. Using a dowel rod, push out the air valve cartridge.



1 - 6mm (1/4") Dowel

Figure 49: Air Valve Cartridge Removal

6. Remove air valve cartridge seal (black) (see Figure 48).
7. Remove front air valve seal (white).

NOTE

► Only remove the front air valve seal (item 3) if there is damage or wear to the seal causing leakage.

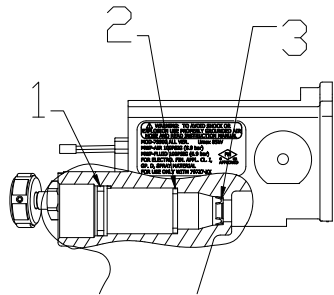

- 1 - Rear Seal
- 2 - Air Valve Cartridge Seal
- 3 - Front Air Valve Seal

Figure 50: Air Valve Cartridge Seal and Front Seal Removal

NOTE

► If you remove the air valve seal, it is highly recommended that it is replaced.

Handle Rebuild

1. Install the front air valve seal using the Special Tool.

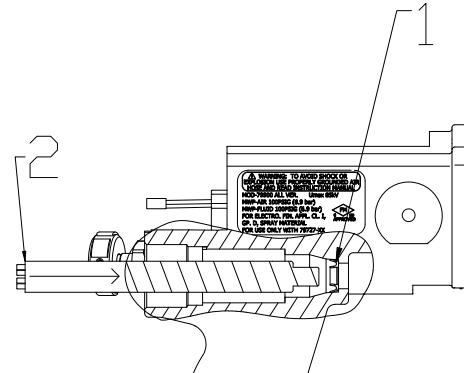
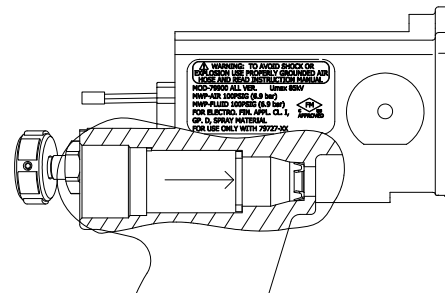

Figure 51: Air Valve Seal Replacement

2. Install the air valve cartridge seal.



- 1 - 79793-00 Jam Nut Tool
- 2 - Front Air Valve Seal - Concave Side to Tool

Figure 52: Cartridge Seal Replacement

3. Install the air valve cartridge. Align the cartridge with tab at 12 o'clock position.

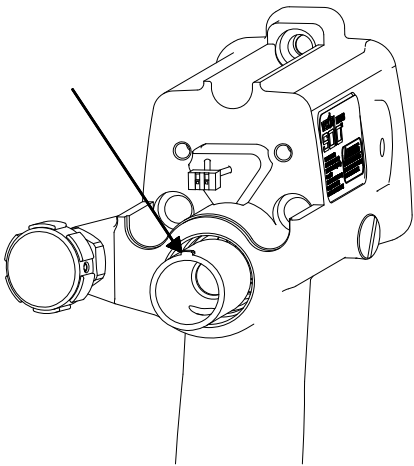

Figure 53: Air Valve Cartridge Alignment

4. Install the rear seal.

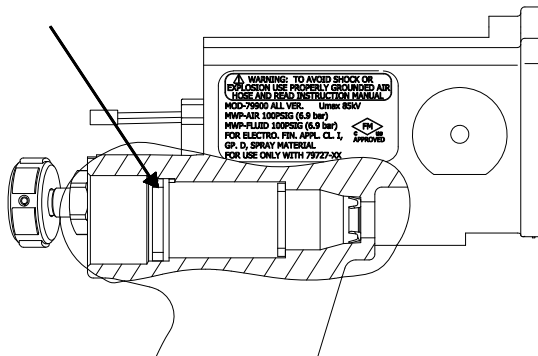

Figure 54: Rear Cartridge Seal Replacement

5. Install air valve.

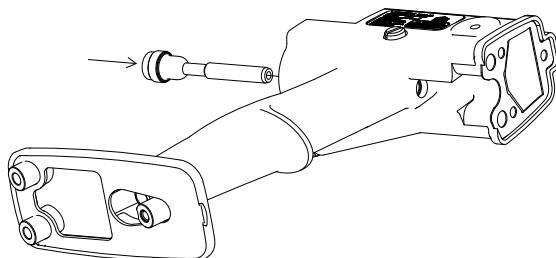

Figure 55: Air Valve Replacement

6. Reinstall barrel.

7. Install power module.

Power Module - Fluid Fitting Removal

1. Remove power module from handle.

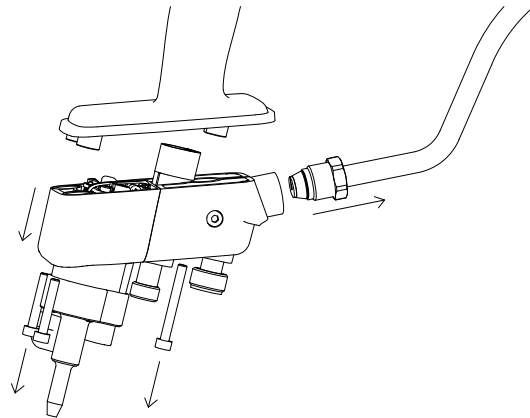

Figure 56: Power Module Removal

2. Remove two (2) screws using a 2.5mm Allen wrench.

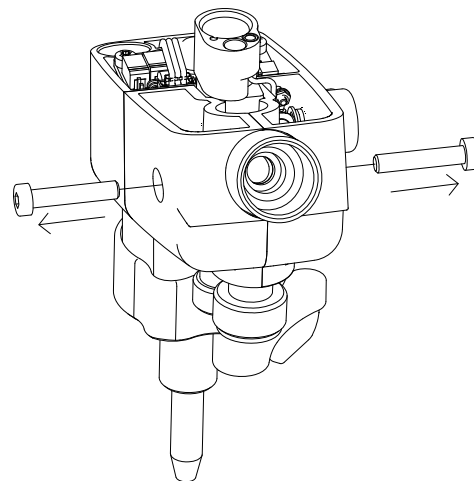

Figure 57: Fluid Fitting Removal

3. Remove the 1/4 module from the 3/4 module. Pull the fluid fitting out.

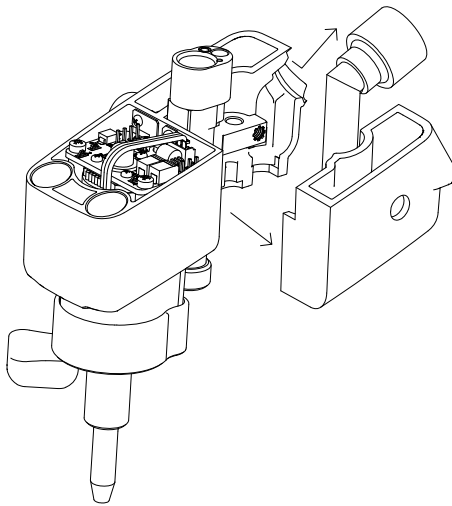

Figure 58: Fluid Fitting Removal

Fitting Replacement

1. Ensure the ground clip is properly installed. Tabs must be touching the air and fluid fitting.

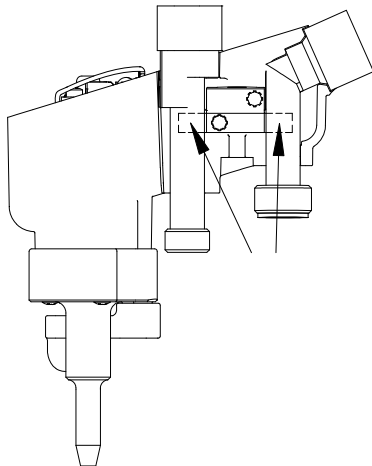

Figure 59: Ground Clip Replacement

! WARNING

- The ground clip must be properly installed such that it touches both the air and fluid fittings.

2. Install the fluid fitting.

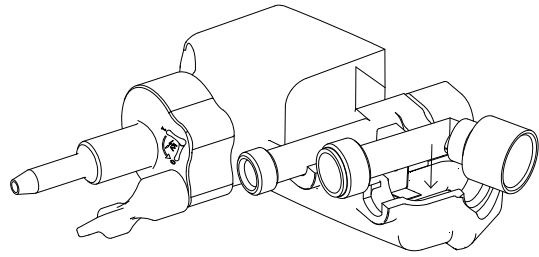

Figure 60: Fluid Fitting Replacement

3. Install the 1/4 module into the 3/4 module and tighten the two (2) screws.

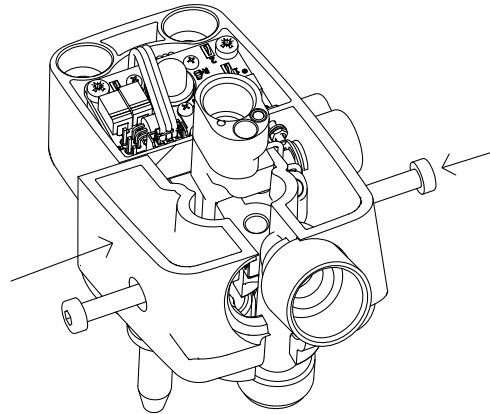

Figure 61: Module Assembly

4. Install power module to handle and tighten three (3) screws. Reinstall the fluid line and torque fluid tube fittings to 40-45 lbs-in.

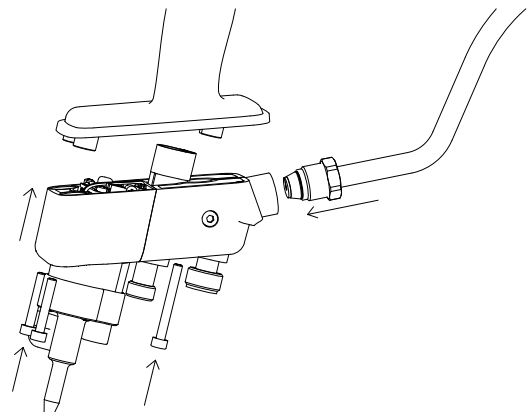

Figure 62: Power Module Assembly

TEST AND MAINTENANCE KIT USAGE (79870-00)

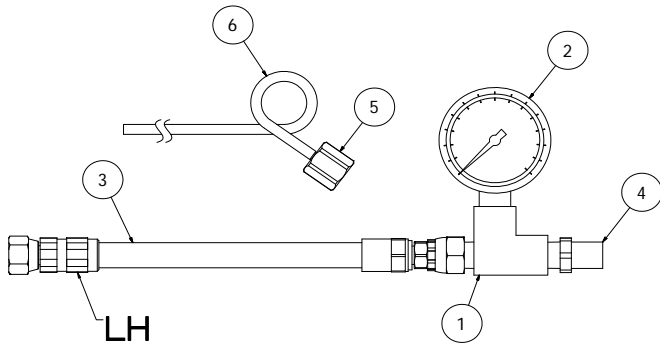

Figure 63: 79870 Test and Maintenance Kit

79870 TEST AND MAINTENANCE KIT	
Item#	Description
1	Brass Tee Fitting
2	100 psi Pressure Gauge
3	6" Air Hose Assembly
4	Left Hand Male Fitting
5	Barb Fitting
6	Tubing

The 79870 Test and Maintenance Kit allows the user to determine the inlet pressure at the base (handle) of the Vector Solo series hand-held applicators. The Test and Maintenance Kit also allows the user to test the 79835 Power Module Assembly on the Vector Solo applicator.

The procedure to test the inlet pressure at the base (handle) of the Vector Solo applicator is as follows (see Figures 63 and 64):

1. Connect the left-hand fitting of the 79727 Air Hose to the male inlet of the Test and Maintenance Kit.
2. Connect the 6" air hose assembly [3] between the brass tee fitting and the gun air inlet.

3. Connect the other end of the air hose to the regulated air supply.

4. Turn on main air. Trigger the applicator with kV switch on high (down position). Read the pressure at the 100 psi pressure gauge. This pressure should be at least 2.75bar (40 psi) with air flowing for proper functioning of the Vector Solo applicator.

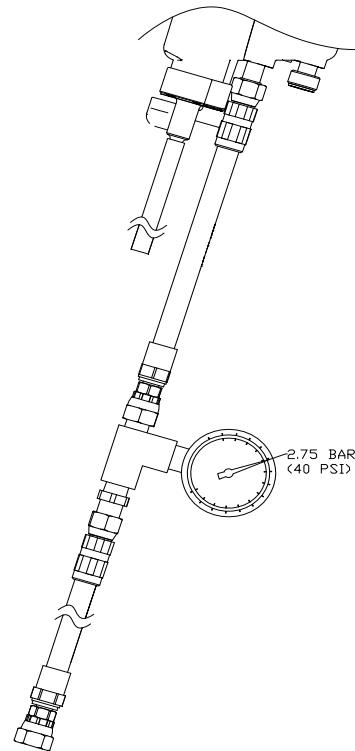

Figure 64: Testing the Pressure at the Base (Handle) of the Applicator

The procedure to test the 79835 Power Module Assembly is as follows:

1. Remove the 79835 Power Module Assembly from the handle.

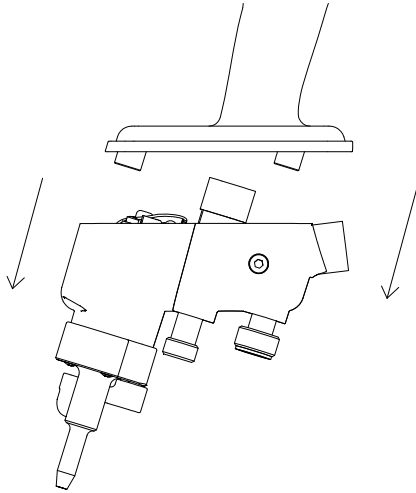

Figure 65: Remove Power Module from Handle

2. Connect the barb fitting [5] to the brass tee fitting [1]. Place the tubing [6] on the end of the barb fitting.

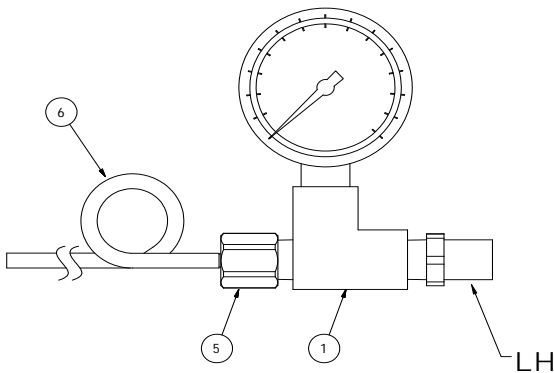

Figure 66: Connect Barb and Tubing to Tee Fitting

3. Connect the left-hand fitting of the 79727 Air Hose to the male inlet of the Test and Maintenance Kit.

4. Insert the tubing [6] into the smaller diameter hole in the top of the air fitting in the power module.

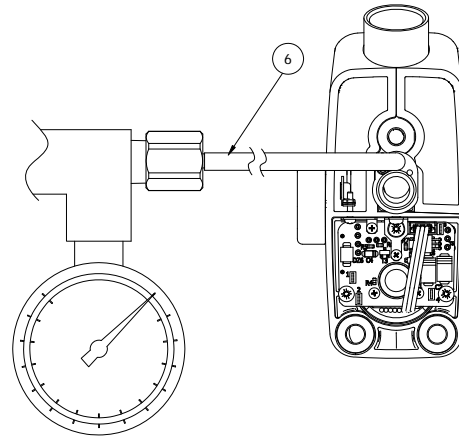

Figure 67: Connect Tubing to the Air Fitting

5. Connect a wire from test point 2 (on the PC board in the power module) to a true earth ground.

6. Connect a digital multi-meter to test points 1 and 2.

TP-1-Test Point #1
 TP-2-Test Point #2
 Ground-True Earth

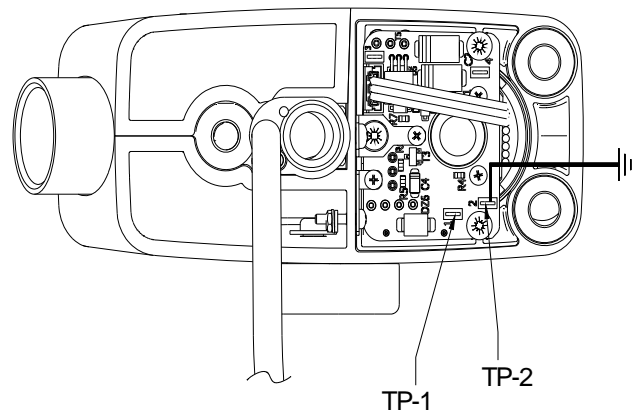

Figure 68: Connect the PC Board to a Digital Multi-Meter and True Earth Ground

7. Connect the 79727 Air Hose to main air.
8. Turn on main air and set the pressure so the pressure gauge [2] in the 79870 Test and Maintenance Kit reads 25 psi (1.7 bar). The voltage kV setpoint lever should be in the high voltage position (down). The digital multi-meter should read approximately 15 VDC.

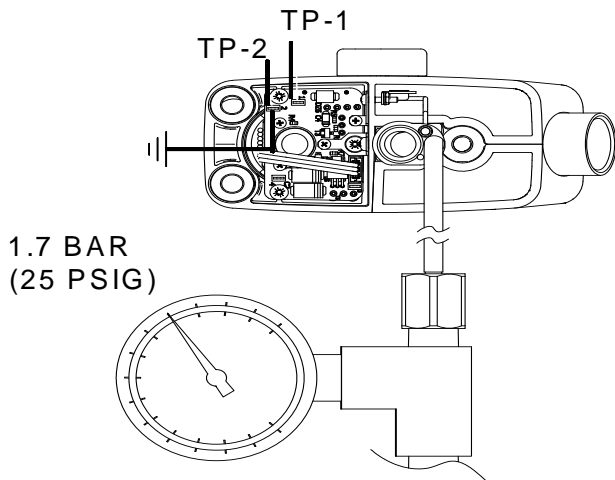

Figure 69: Set Pressure Gauge to 25 psi

9. If the voltage is outside this range, there is a problem with the power module circuitry. If the voltage range is acceptable the power module is operating correctly, there is an issue with either the cascade or the wire connections leading to it.

AIR HOSE MAINTENANCE

Air Hose -Ground Wire End

1. Cut the end of the air hose so that end is square.
2. Slide the sleeve and compression ring onto the air hose end.

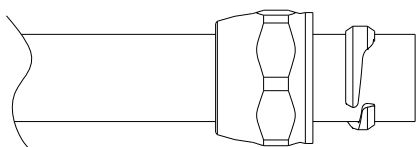

Figure 70: Sleeve and Compression Ring

3. Push the stem of the fitting all the way into the into the air hose.

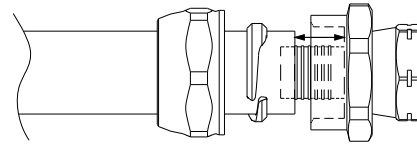

Figure 71: Ground Fitting Insertion

4. Slide the compression ring and the sleeve into the fitting body and tighten.

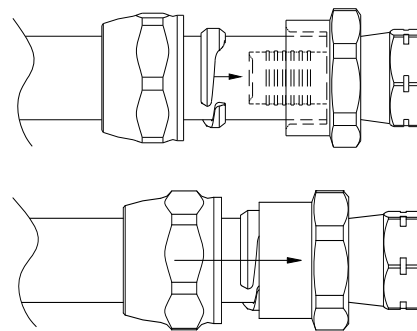

Figure 72: Sleeve Tightening

Air Hose -Applicator End

1. Cut the end of the air hose so that end is square.
2. Install the 79930 fitting (std) or 79868 (qd) into the hose end. Lightly lubricate the barb end of the fitting with LSCH-0009 di-electric lubricant. Push the fitting into the air hose up to the threads on the stem.

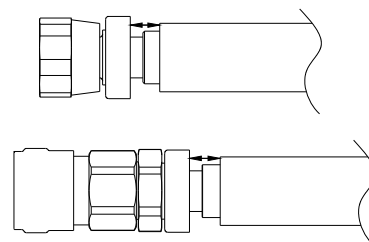

Figure 73: Fitting Insertion

3. With the 79330 fitting, hold the hose in one hand and press a 6mm or 1/4" t-handle allen wrench into the hex in the part while turning clockwise. Tighten till cap is approximately .8 mm (1/32") from the swivel nut.

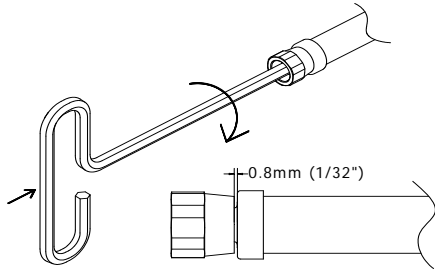

Figure 74: Tightening 79930 Fitting

4. With the 79868 DQ fitting, hold the hose in one hand and press against a firm surface while turning the body wrench flat clockwise. Tighten till cap is approximately .8 mm (1/32") from the QD base.

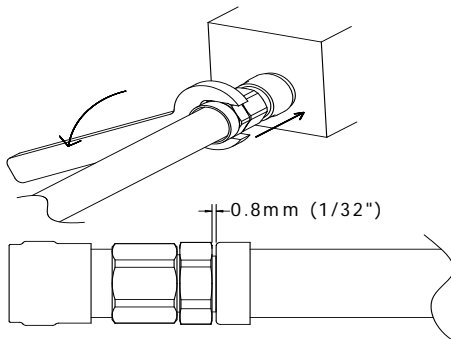

Figure 75: Tightening 79868 QD Fitting

Resistance Test

1. If the hose is changed, the resistance must be checked. Using a Meg Ohm meter at 1000V measure the resistance from the lug of the ground wire to the body of the QD (79868) or the swivel nut (79930). The reading must be less than .5 Mega Ohms resistance end to end.

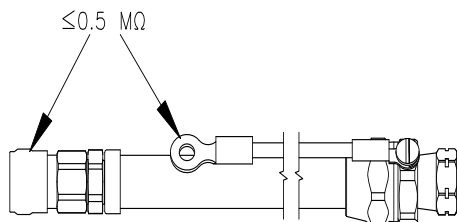

Figure 76: Air Hose Resistance Test

NOTES

TROUBLESHOOTING GUIDE

General Problem	Possible Cause	Solution
ELECTRICAL		
No kV	<ol style="list-style-type: none"> 1. On-Off lever in wrong position 2. Low pressure 3. No ground connection 4. Cascade not functioning 5. Three (3) screws at base of handle are loose 6. Failed power module 	<ol style="list-style-type: none"> 1. Ensure the On/Off lever is in the On position. 2. Ensure 40 psig (2.75 bar) at the applicator handle with applicator triggered. 3. Ensure the air hose is properly grounded to the earth ground. 4. Ensure cascade is functioning properly. 5. Tighten screws to ensure proper assembly. 6. Ensure module is properly functioning.
Low kV	<ol style="list-style-type: none"> 1. Fluid remnants in the air passage 2. Wrong solvent used for final cleaning process 3. Add sufficient air pressure at handle 	<ol style="list-style-type: none"> 1a. Clean air passages with non-polar solvent. 1b. Ensure fluid nozzle is properly tightened. 2. Use non-polar solvent for the final cleaning process. 3. Ensure 2.8 bar (40 psig) at the handle with applicator triggered.
INADEQUATE DELIVERY		
No Fluid Flow	<ol style="list-style-type: none"> 1. No pressure 2. Fluid tube may be plugged 3. Fluid nozzle may be plugged 4. Electrode not properly assembled 5. Material too viscous 	<ol style="list-style-type: none"> 1. Ensure pressure at the fluid line at the applicator. 2. Replace or clean. 3. Replace or clean. 4. Reassemble tightened to stop. 5. Thin the material to a viscosity that is sprayable.
Spray Performance	<ol style="list-style-type: none"> 1. No adjustment of fan pattern 2. Poor atomization 3. Fluid in Air Passages 	<ol style="list-style-type: none"> 1a. Restrictor left out of barrel. 1b. The three (3) 5mm barrel to handle screws are not properly tightened. 2. Ensure atomization air passages are clear of all foreign particles. 3. Ensure the fluid nozzle is properly tightened to 35-40 lbs-in (3.9-4.5 Nm)

PARTS IDENTIFICATION

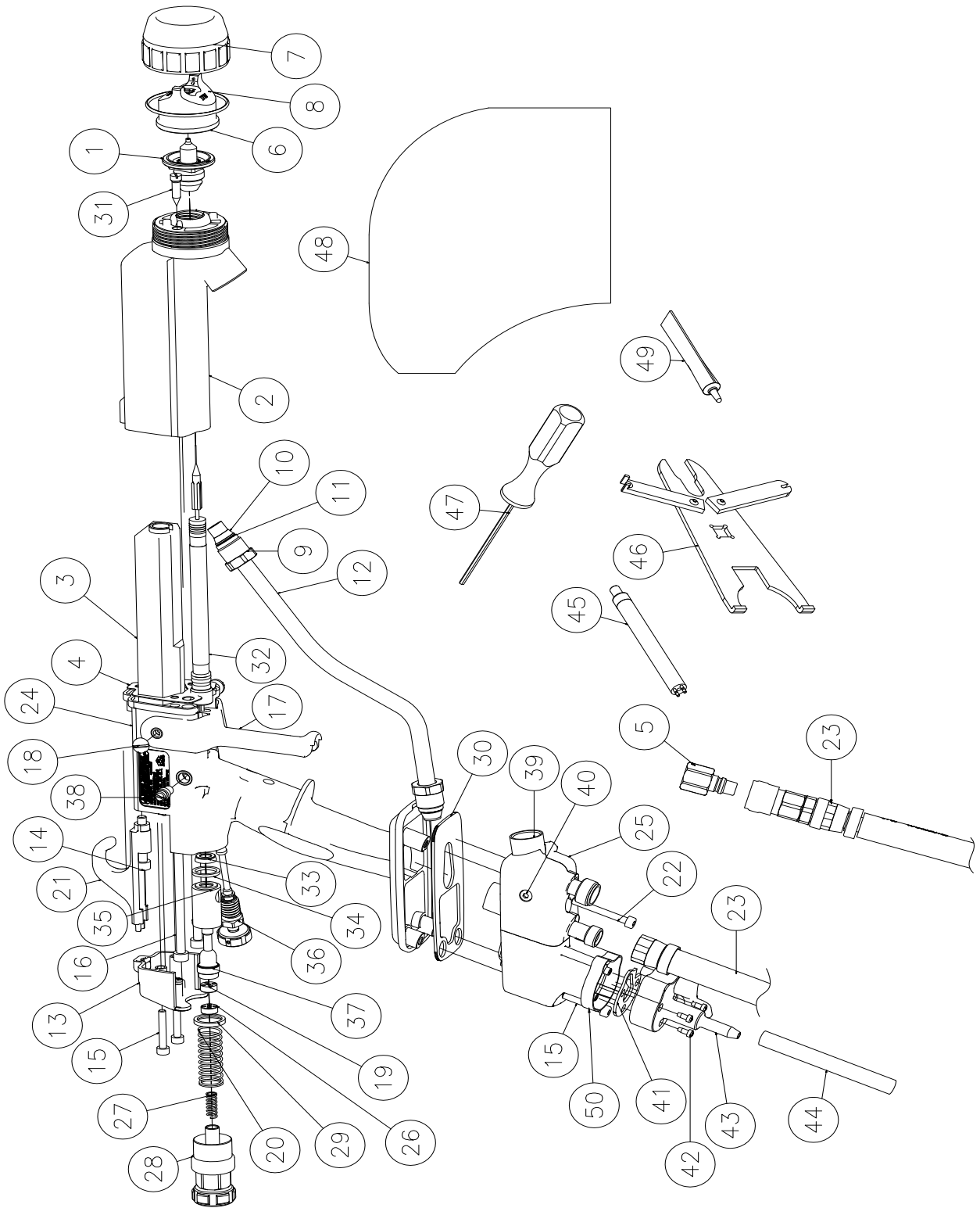

Figure 77: Vector Solo Applicators Parts Breakdown

**VECTOR SOLO SOLVENTBORNE APPLICATOR -
PARTS LIST (Figure 77)**

Item #	Part #	Description	Qty
1	Table D - "D2"	Nozzle, Fluid, 1.4mm	1
2	79736-00	Assembly, Barrel, Vector Solo	1
3	79600-00	Cascade Assembly	1
4	79832-00	Gasket, Barrel	1
5	79869-00	Stem, Male QD (Included with QD ordered Models)	1
6	Table D - "D1"	Cap, Air, 65R	1
7	79724-00	Nut, Retaining, Air Nozzle	1
8	LSOR0005-17	O-Ring, Teflon Encapsulated	1
9	79385-00	Nut, Connector, Hose	2
10	EMF-202-05	Ferrule, Back 3/8" Tube	2
11	EMF-203-05	Ferrule, Front 3/8" Tube	2
12	79878-02	Tube, Fluid Inlet, 3.2mm ID (.125")	1
	79878-03	Tube, Fluid Inlet, 3.4mm ID (.250")	1
	Table E - "E"	Tube, Fluid, Inlet, 2.4mm ID (.093"), 232mm, 9 1/8" Lg. (Standard W/Applicator)	1
13	79816-00	Assembly, Rear Cover	1
14	79798-03	SHCS, M5 X 30"	1
15	79799-01	Socket Head Cap Screw, M4 X 25mm	4
16	79798-02	Socket Head Cap Screw, M5 X 80mm	2
17	Table C - "C"	Assembly, Trigger	1
18	79454-00	Screw, Trigger Retention	2
19	79762-00	Nut, Fluid Jam, Front	1
20	79774-00	Spring, Air Valve Return	1
21	79701-00	Hook, Molded	1
22	79799-02	SHCS, M4 X 30mm	1
23	Table A - "A"	Assembly, Air Hose, Solo (10, 20, and 30m Lengths)	1
24	79833-00	Assembly, Handle, Vector Solo (Includes Items 33, 34, 35, 36, 37, and 38)	1
24A	79833-01	Assembly, Handle Only	1
25	79835-00	Assembly, Power Module (Includes Items 39, 40, 41, 42, and 43)	1
26	79768-00	Nut, Fluid Jam, Spring Guide	1
27	78636-00	Spring	1
28	79789-00	Assembly, Rear Fluid Adjustment	1
29	79781-00	Seal, Adjustment Bushing	1
30	79837-00	Gasket, Handle to Power Module	1
31	Table D - "D3"	Pressure Reducer, Atomizing Air, Vector Solo (Yellow)	1
32	79853-00	Kit, Shaft Assembly, 2 Piece Needle, Vector Solo	1
33	79760-00	Seal, Air Valve	1
34	79001-09	O-Ring, Solvent Proof	1
35	79770-00	Cartridge, Air Valve	1
36	79759-00	Assembly, Fan Air Adjust Valve	1
37	79772-00	Assembly, Air Valve	1
38	79847-00	Valve, Atom Adjust	1
	79847-01	Plug, Atom (Std. installed in applicator)	1
39	79755-00	Fluid Inlet	1

(Continued On Next Page)

VECTOR SOLO SOLVENTBORNE APPLICATOR - PARTS LIST (Cont.) (Figure 77)			
Item #	Part #	Description	Qty
40	79814-00	SHCS, M4 X 20mm	1
41	79836-00	Gasket, Exhaust	1
42	79805-00	Screw	3
43	79843-00	Assembly, Exhaust Housing	1
44	79861-00	Hose, Exhaust	1
45	79793-00	Jam Nut Removal/Seal Install Tool	1
46	79854-00	Wrench, Vector Solo (Packing Adjust, Barrel Removal, Nozzle Removal)	1
47	79862-01, -02, -03	Hex Driver (2.5mm, 3mm, and 4mm)	1
48	79529-00-K5	Applicator Cover	1
49	LSCH0009-00	Dielectric Grease	1
50	79881-00	Gasket, Exhaust, Wraparound	1
51	80003-00-K10	Cover, Solo Power Module	1

VECTOR SOLO RS90-AS MODEL IDENTIFICATION

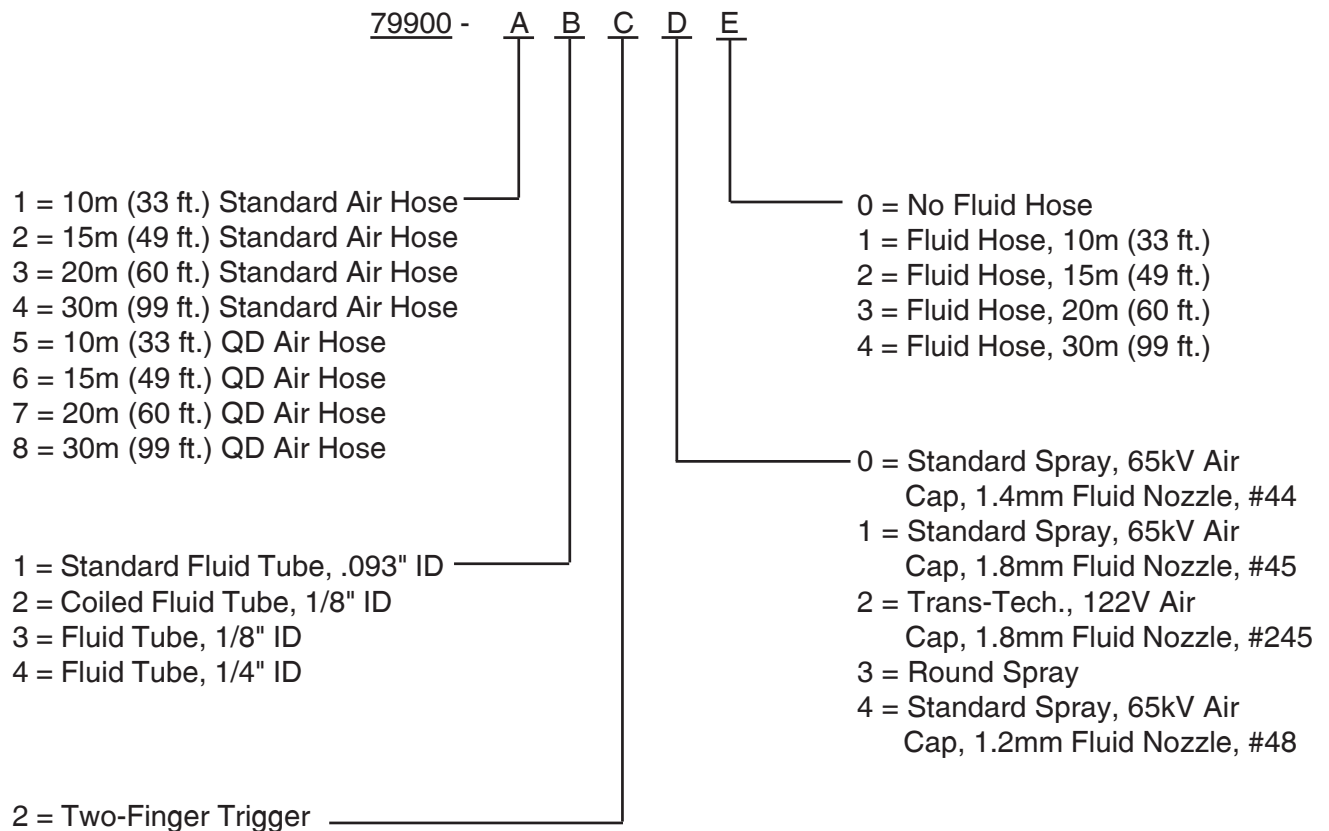

TABLE A - Air Hose Length and Air Hose Type			
"A" Dash #	Description	Description	"A" Air Hose/ Stem
1	10m (33-ft.)	Standard Air Hose	79727-10 / -----
2	15m (49-ft.)	Standard Air Hose	79727-15 / -----
3	20m (66-ft.)	Standard Air Hose	79727-20 / -----
4	30m (99-ft.)	Standard Air Hose	79727-30 / -----
5	10m (33-ft.)	Air Hose W/Quick-Disconnect / QD Stem	79727-11/ 79869-00
6	15m (49-ft.)	Air Hose W/Quick-Disconnect / QD Stem	79727-16 / 79869-00
7	20m (66-ft.)	Air Hose W/Quick-Disconnect / QD Stem	79727-21/ 79869-00
8	30m (99-ft.)	Air Hose W/Quick-Disconnect / QD Stem	79727-31/ 79869-00

TABLE B - FLUID TUBE SELECTION		
B Dash #	Description	"B"
1	Standard Fluid Tube, .093" ID X 3/8" OD	79878-01
2	Coil Fluid Hose, .125" ID, Low Flow	79871-00
3	Standard Fluid Tube, 1/8" ID X 3/8" OD	79878-02
4	Standard Fluid Tube, 1/4" ID X 3/8" OD	79878-03

TABLE C - TRIGGER SELECTION		
C Dash #	Description	"C"
2	2-Finger Trigger	79787-00

TABLE D - SPRAY SELECTION				
D Dash #	Description	"D1"	"D2"	"D3"
0	Standard Spray, 65V Air Cap, 1.4mm Fluid Nozzle, #44	79374-65	79377-44	79809-00
1	Standard Spray, 65V Air Cap, 1.8mm Fluid Nozzle, #45	79374-65	79377-45	79809-00
2	Trans-Tech., 122V Air Cap, 1.8mm Fluid Nozzle, #245	79374-122	79552-245	74963-06
3	Round Spray	79962-00	79959-00	74963-05
4	Standard Spray, 65V Air Cap, 1.2mm Fluid Nozzle, #48	79374-65	79377-48	79809-00

TABLE E - FLUID HOSE SELECTION		
E Dash #	Description	"E"
0	No Fluid Hose	--
1	Fluid Hose, 10m (33 ft.)	79548-10
2	Fluid Hose, 15m (49 ft.)	79548-15
3	Fluid Hose, 20m (60 ft.)	79548-20
4	Fluid Hose, 30m (99 ft.)	79548-31

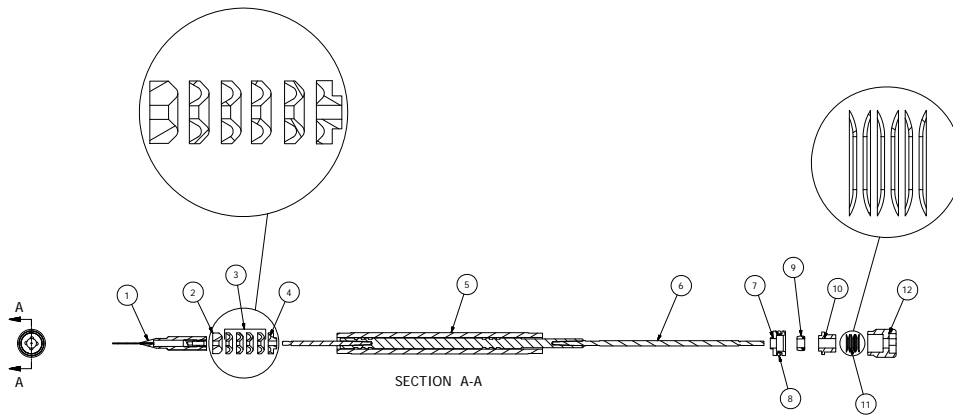

Figure 78: 79853-00 Needle Shaft 2k With Adjustable Packings

79853-00 NEEDLE SHAFT - PARTS LIST (Figure 78)			
Item #	Part #	Description	Qty
1	70430-01	Electrode, High Wear	1
2	74653-00	Adapter, Male Chevron	1
3	14323-00	Seal, 3/8" Diameter Chevron	4
4	18821-00	Adapter, Female Chevron	1
5	18842-01	Tube, Packing	1
6	79747-00	Assembly, Needle Shaft, Solo 85KV	1
7	78629-00	Retainer, Needle Seal, Rear	1
8	79001-06	O-Ring, Solvent Proof	1
9	10051-05	Cup Seal, Spring Loaded	1
10	78630-00	Spacer, Seal	1
11	17390-04	Washer, Spring, Belleville	6
12	78631-00	Nut, Packing	1

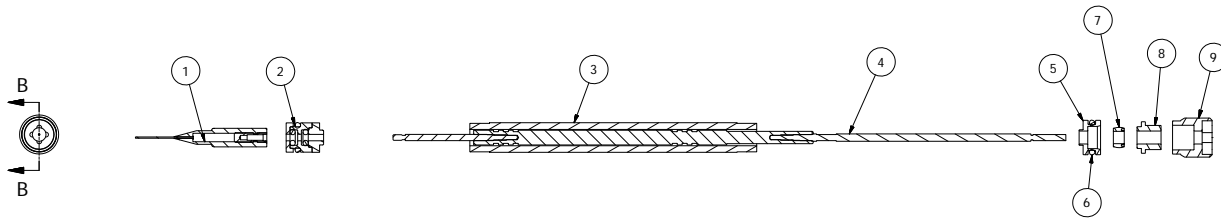

Figure 79: 79853-01 Needle Shaft With Non-Adjustable Packings, 1K

79853-01 NEEDLE SHAFT, NON-ADJUSTABLE PACKINGS, FOR 1K ONLY- PARTS LIST (Figure 79)

Item #	Part #	Description	Qty
1	70430-01	Electrode, High Wear	1
2	78626-00	Assembly, Seal Cartridge, Non- Adjustable	1
3	18842-01	Tube, Packing	1
4	79747-00	Assembly, Needle Shaft, Solo 85kV	1
5	78629-00	Retainer, Needle Seal, Rear	1
6	79001-06	O-Ring, Solvent Proof	1
7	10051-05	Cup Seal, Spring Loaded	1
8	78630-00	Spacer, Seal	1
9	78631-00	Nut, Packing	1

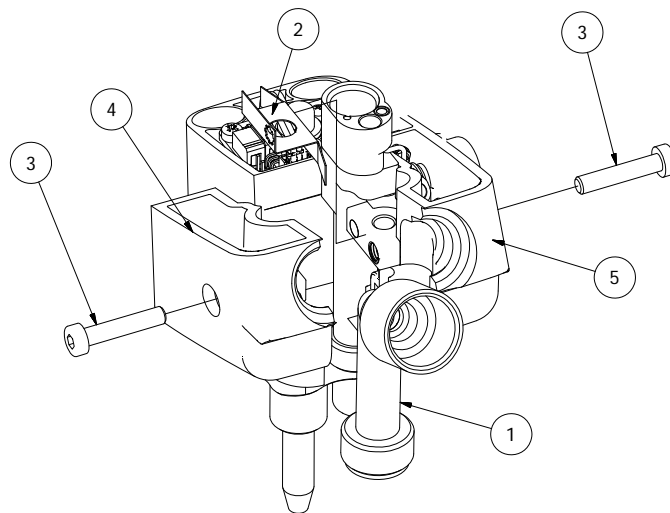

Figure 80: Power Module Replaceable Parts

POWER MODULE REPLACEABLE PARTS - PARTS LIST (Figure 80)

Item #	Part #	Description	Qty
1	79755-00	Fluid Inlet	1
2	79746-00	Grounding Clip	1
3	79814-00	SHCS, 4mm X 20mm Lg.	2
4	(Ref.)	1/4 Power Module	--
5	(Ref.)	3/4 Power Module	--

ACCESSORIES

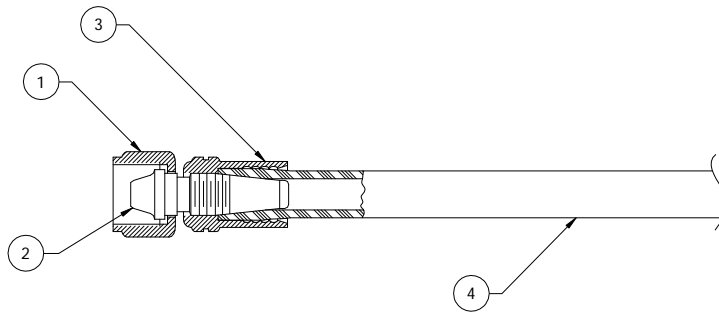

Figure 81: Fluid Hose - Optional

FLUID HOSE - PARTS LIST (OPTIONAL) (Figure 81)			
Item #	Part #	Description	Qty
	79548-10	Fluid Hose Assembly, 10m (33 ft.)	
	79548-15	Fluid Hose Assembly, 15m (49 ft.)	
	79548-20	Fluid Hose Assembly, 20m (66 ft.)	
	79548-31	Fluid Hose Assembly, 30m (99 ft.)	
1	14599-00	Nut	1
2	7623-00	Union Stem	1
3	7617-00	Ferrule	1
4	77031-XX	Bulk Hose, Fluid	XX

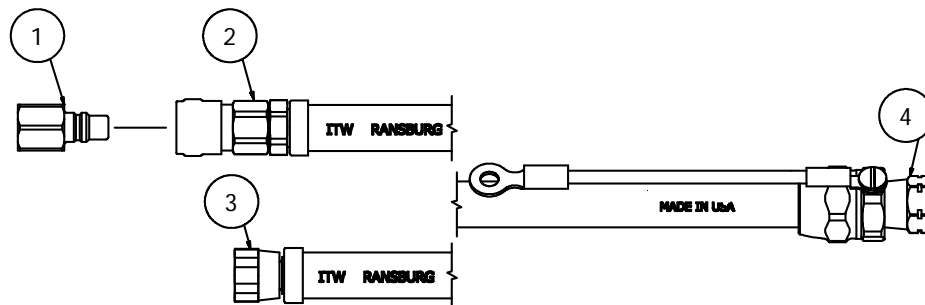
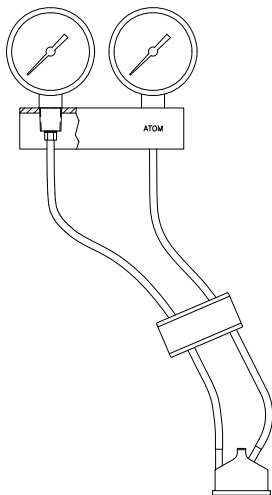

Figure 82: Air Hose Assembly Parts

AIR HOSE ASSEMBLY - PARTS LIST (Figure 82)			
Item #	Part #	Description	Qty
1	79869-00	Stem, Quick Disconnect Air Fitting (1/2-20 LH)	1
2	79868-00	Assembly, Quick Disconnect Fitting	1
3	79930-00	Hose Fitting Assembly (1/2-20 LH)	1
4	79938-00	Assembly, Ground Fitting	1

AIR HOSE ASSEMBLIES	
Part #	Description
79727-10	Standard Air Hose Assembly, 10 meter (33 foot)
79727-11	QD Air Hose Assembly, 10 meter (33 foot)
79727-11-SS	QD Air Hose Assembly with Stem, 10 meter (33 foot)
79727-15	Standard Air Hose Assembly, 15 meter (49 foot)
79727-16	QD Air Hose Assembly, 15 meter (49 foot)
79727-16-SS	QD Air Hose Assembly with Stem, 15 meter (49 foot)
79727-20	Standard Air Hose Assembly, 20 meter (66 foot)
79727-21	QD Air Hose Assembly, 20 meter (66 foot)
79727-21-SS	QD Air Hose Assembly with Stem, 20 meter (66 foot)
79727-30	Standard Air Hose Assembly, 30 meter (99 foot)
79727-31	QD Air Hose Assembly, 30 meter (99 foot)
79727-31-SS	QD Air Hose Assembly with Stem, 30 meter (99 foot)
79727-51	QD Air Hose Assembly, 50 meter (150 foot)
79727-51-SS	QD Air Hose Assembly with Stem, 30 meter (99 foot)
79727-99	Whip Hose, (150mm, 6 inch)



AIR CAP TEST KIT - (OPTIONAL) (Figure 83)	
Part #	Description
74035-27	Air Cap Test Kit, 65 V
74035-28	Air Cap Test Kit, 98 V

Figure 83: Air Cap Test Kit - Optional

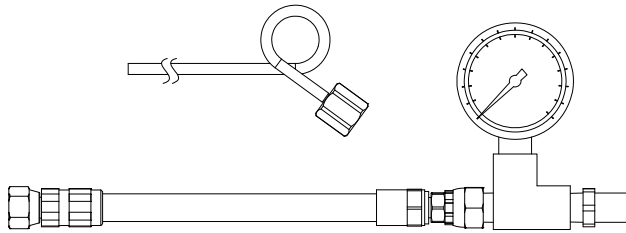

Figure 84: Test and Maintenance Kit - Optional

TEST AND MAINTENANCE KIT - (OPTIONAL) (Figure 84)	
Part #	Description
79870-00	Test and Maintenance Kit

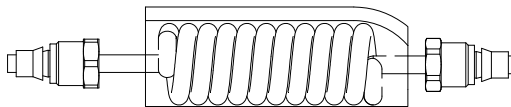

Figure 85: Coiled Fluid Tube

COILED FLUID TUBE - (OPTIONAL) (Figure 85)	
Part #	Description
79871-00	Coiled Fluid Tube, 3.2mm (.125") ID, 16 Coils
79871-01	Coiled Fluid tube, 3.2mm (.125") ID, 12 Coils
79890-00-K5	Cover, Coiled Fluid Tube, Kit of 5

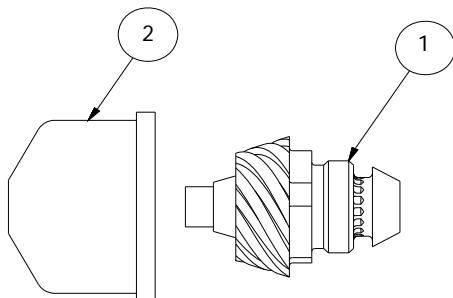

Figure 86: Round Spray

ROUND SPRAY - (OPTIONAL) (Figure 86)	
Part #	Description
79959-00	Round Spray Fluid Nozzle
79962-00	Round Spray Air Cap

SHORT STOPPER HOSE ASSEMBLY

A short stopper hose assembly is now available for the Vector Solo applicator. The short stopper is used when the coiled fluid tube (p/n 79871-00) does not adequately isolate highly conductive solvent based materials from ground. In those applications, the short stopper is used. The following assemblies are available for purchase:

SHORT STOPPER ASSEMBLIES	
Part #	Description
77821-12	1.2m (4') Long 3/16" ID Grounded Fluid Hose Assembly
77821-30	3.0m (10') Long 3/16" ID Grounded Fluid Hose Assembly
77821-76	7.6m (25') Long 3/16" ID Grounded Fluid Hose Assembly
77822-12	1.2m (4') Long 1/4" ID Grounded Fluid Hose Assembly
77822-30	3.0m (10') Long 1/4" ID Grounded Fluid Hose Assembly
77822-76	7.6m (25') Long 1/4" ID Grounded Fluid Hose Assembly

In order to use these short stopper hoses, the conductive fluid conversion kit (79891-00) must be purchased as well.

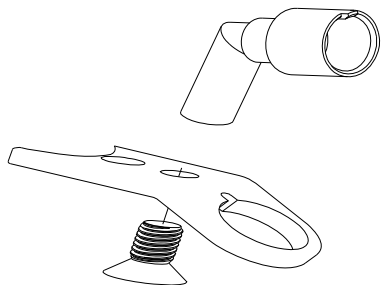

Figure 87: Conductive Fluid Conversion Kit

In order for the short stopper assembly to work properly, it must be correctly installed onto a current Vector Solo applicator. The following steps describe how to convert a standard Vector Solo applicator to use a short stopper assembly.

Converting a Standard Vector Solo To Use a Short Stopper Assembly

1. First, remove the fluid tube from the fluid fitting. Second, remove the three (3) screws from the base of the power module. Finally, remove the power module from the handle by pulling straight down.

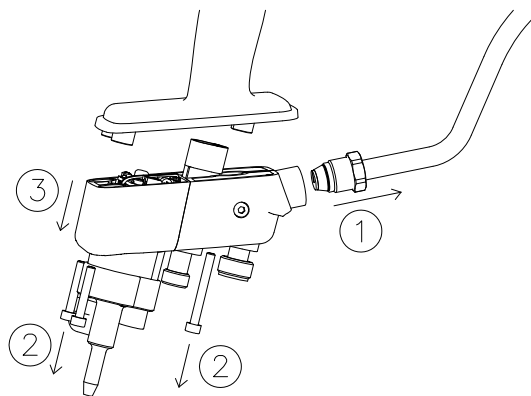

Figure 88: Remove Power Module From Handle

2. Next, remove the two (2) screws from the sides of the power module.

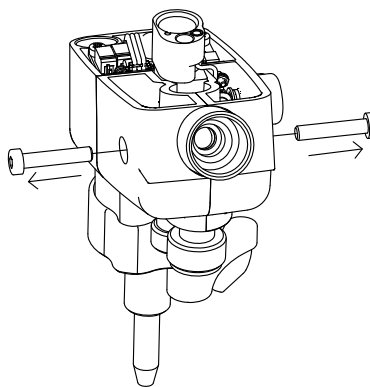

Figure 89: Remove Screws

3. Pull apart the two pieces of the power module and remove the fluid fitting.

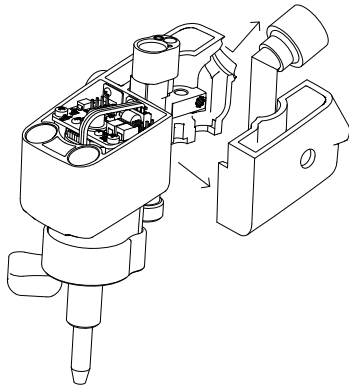

Figure 90: Remove Fluid Fitting

5. Place the two power module pieces together and re-install the two (2) screws in sides of the power module.

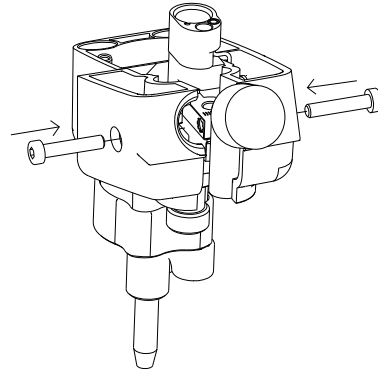

Figure 92: Install Screws

4. Install the new short stopper fitting [1].

NOTE

- Ensure the ground strap [2] is installed in the power module and makes contact with the new short stopper fitting [1] as well as the air fitting [3].

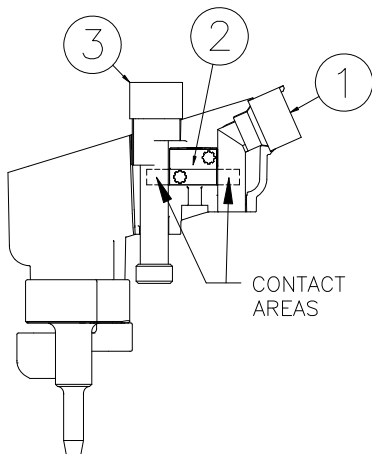

Figure 91: Install New Short Stopper Fitting

6. Install the hose bracket [1] onto the new short stopper fitting [2] using the bracket nut [3].

NOTE

- Make sure to align the notch on the new short stopper fitting [2] with the groove on the hose bracket [1].

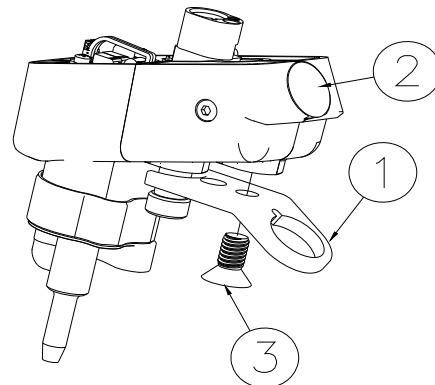

Figure 93: Install Bracket and Nut

7. Install the short stopper hose into the hose bracket following these steps:

- a. Remove the two (2) ferrules [7 and 8], connector nut [6], Nylo-Seal nut [5], and the thin jam nut [4] from the short stopper hose [1]. Do not discard. These pieces will be reinstalled onto the short stopper hose.

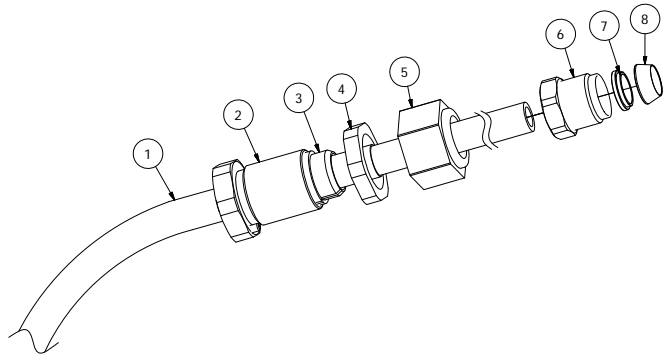

Figure 94: Short Stopper Hose Assembly

SHORT STOPPER HOSE ASSEMBLY PARTS LIST	
Item	Description
1	Short Stopper Hose
2	Bulkhead Connector
3	Conductive Ferrule
4	Thin Jam Nut
5	Nylo-Seal Nut
6	Connector Nut
7	Ferrule, Front, 3/8" Tube
8	Ferrule, Back, 3/8" Tube

- b. Insert the short stopper hose [1], with the conductive ferrule [3], and bulkhead connector [2] still on the hose, through the hole in the hose bracket [9].

NOTE

- Make sure to align the pin on the bulkhead connector [2] with the hole on the hose bracket [9].

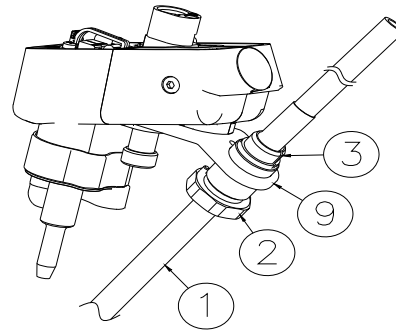

Figure 95: Install Hose Into Bracket

- c. Tighten the thin jam nut [4] onto the bulkhead connector [2]. Tighten the Nylo-Seal nut [5] onto the bulkhead connector [2].

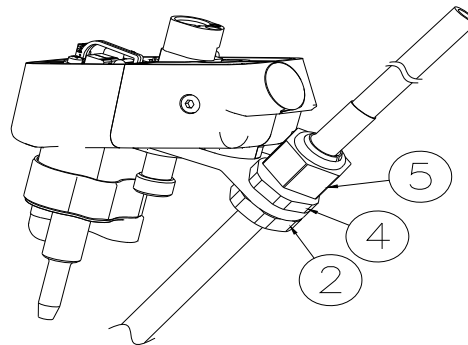

Figure 96: Tighten Hose Onto Bracket

- d. Re-install the power module onto the handle and tighten the three (3) screws.

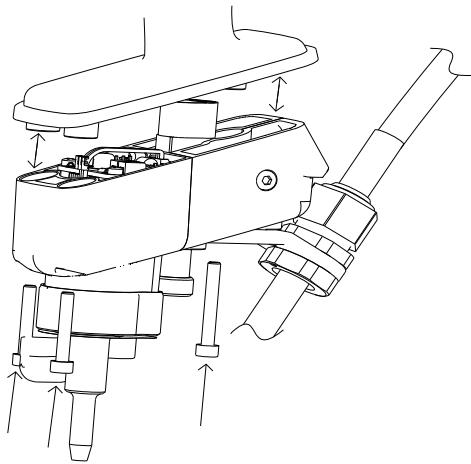

Figure 97: Install Power Module On Handle

- e. Place the connector nut [6] and two (2) ferrules [7 and 8] onto the short stopper hose. Insert hose into the barrel and tighten the connector nut [6].

NOTE

► Hose may need to be trimmed to proper length (approximately 213mm (8 3/8") measured from the top face of the bracket).

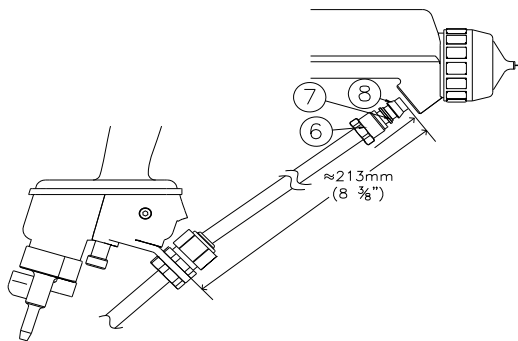

Figure 98: Install Hose Onto Barrel

The 79658-00 Gasket Kit is available for the Vector Solo. This kit includes all of the gaskets required for an applicator rebuild.

79658-00 GASKET KIT - PARTS LIST	
Part #	Description
79837-00	Gasket, Handle to Power Module
79832-00	Gasket, Barrel
79836-00	Gasket, Exhaust
79881-00	Gasket, Exhaust, Wraparound
79876-00	Label, Voltage On/Off, Solo

The 79651-00 Installation and Setup Kit is available for the Vector Solo. This kit includes all equipment necessary for the installation, setup, and maintenance of the Vector Solo applicator. This kit includes:

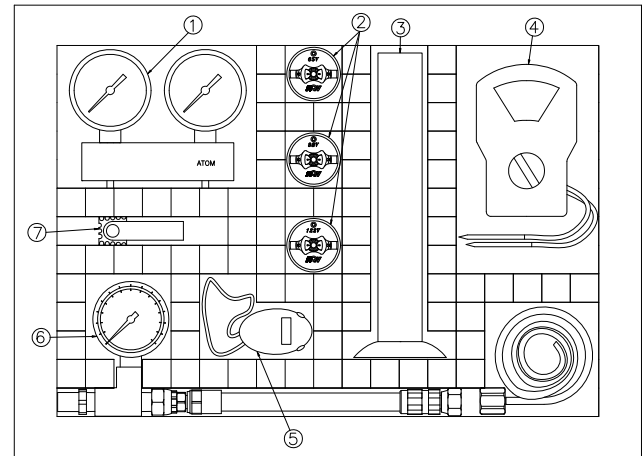
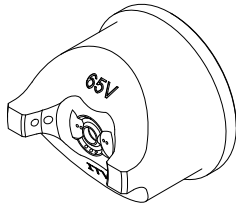

Figure 99: Installation and Setup Kit

79651-00 INSTALLATION AND SETUP KIT - PARTS LIST	
Item #	Description
1	Cap Pressure Test Gauges
2	Test Air Caps (65V, 98V, 122V)
3	100 ml Graduated Cylinder
4	Analog Voltmeter
5	Stop Watch
6	Test and Maintenance Kit
7	Wet Film Gauge

PARTS COMPARISON



79374-65 Standard Air Spray Air Cap

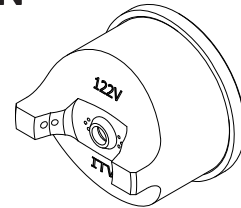

79374-122 Trans-Tech. Air Spray Air Cap

Standard Air Spray Nozzles have a number between 44 and 148; Trans-Tech. Air Spray Nozzles have a number between 244 and 348.

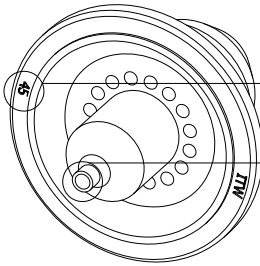

79377-XX Standard Air Spray Fluid Nozzle

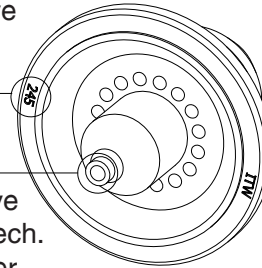

79552-XXX Trans-Tech. Air Spray Fluid Nozzle

Standard Air Spray Nozzles have a longer, narrower tip; Trans-Tech. Air Spray Nozzles have a shorter, wider tip, and have a shorter overall length.

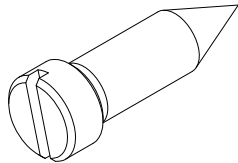

79809-00 Standard Air Spray Restrictor

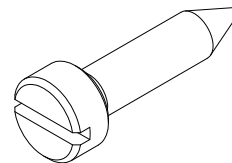

74963-06 Trans-Tech. Air Spray Restrictor

TRANS-TECH. ATOMIZATION - PARTS LIST

Item #	Part #	Description	Qty
1	79379-00	Nut, Retaining, Air Nozzle	1
2	79374-65	Standard Air Spray Cap, Air	1
	79374-122	Trans-Tech. Air Spray Cap, Air (Included in 79555 Kit)	
3	79377-XX	Standard Air Spray Nozzle, Fluid	1
	79552-XXX	Trans-Tech. Air Spray Nozzle, Fluid (Included in 79555 Kit)	
4	79809-00	Standard Air Spray Restrictor, Yellow, Vector	1
	74963-06	Trans-Tech. Air Spray Restrictor, Green(Included in 79555 Kit)	

79555 TRANS-TECH. CONVERSION KITS AVAILABLE		
Kit Part No.	Fluid Nozzle Part No.	Description
79555-244	79552-244	1.4mm (.055") Acetal
79555-245	79552-245	1.8mm (.070") Acetal
79555-247	79552-247	0.7mm (.028") Acetal
79555-344	79552-344	1.4mm (.055") Peek
79555-345	79552-345	1.8mm (.070") Peek
79555-347	79552-347	0.7mm (.028") Peek

All Kits Include: 79374-122 Air Cap, 79809-00 Restrictor (yellow), and chosen Fluid Nozzle.

Kit 79555 replaces parts:

- 79809-00 Restrictor
- 79377-45 Fluid Nozzle
- 79374-65 Air Cap

NOTE: For additional information on solvent Viscosities and Conversion, refer to Technical Manual IL-307 @ www.itwransburg.com.

VECTOR SOLO RECOMMENDED SPARE PARTS (Quantities Per Applicator)		
Part #	Description	Qty
79377-44	Nozzle, Fluid, 1.4mm	2
79736-00	Assembly, Barrel, Vector Solo	1
79600-00	Cascade Assembly	1
79832-00	Gasket, Barrel	1
79001-09	O-Ring, Solvent Proof	2
79374-65	Cap, Air, 65R	2
79724-00	Nut, Retaining, Air Nozzle	1
LSOR0005	O-Ring, Teflon Encapsulated	1
EMF-202-05	Ferrule, Back, 3/8" Tube	2
EMF-203-05	Ferrule, Front, 3/8" Tube	2
79878-02	Tube, Fluid Inlet, 3.2mm ID (.125")	1
79878-03	Tube, Fluid Inlet, 3.4mm ID (.250")	1
79878-01	Tube, Fluid Inlet, 2.4mm ID (.093"), 232mm, 9 1/8" Lg. (Standard W/Applicator)	1
79787-00	Assembly, Trigger	1
79454-00	Screw, Trigger Retention	2
79768-00	Nut, Fluid Jam, Front	1
79744-00	Spring, Air Valve Return	1
79835-00	Assembly, Power Module (Includes Items 39, 40, 41, 42, and 43)	1
79768-00	Nut, Fluid Jam, Spring Guide	1
78636-00	Spring	1
79781-00	Seal, Adjustment Bushing	1
79837-00	Gasket, Handle to Power Module	1
79809-00	Pressure Reducer, Atomizing Air, Vector Solo (Yellow)	1
79853-00	Kit, Shaft Assembly, 2-Piece Needle, Vector Solo	1
79760-00	Seal, Air Valve	1
79847-00	Valve, Compensation Atomizing	1
79755-00	Fluid Inlet	1
79836-00	Gasket, Exhaust	1
79843-00	Assembly, Exhaust Housing	1
79529-00-K5	Applicator Cover (Kit of 5)	2
LSCH0009-00	Dielectric Grease	2
80003-00-k10	Cover, Solo Power Module (Kit of 10)	1

**FLUID NOZZLE SELECTION
STD SPRAY CHART**

Fluid Nozzle Part #	Orifice ID	Nozzle Material
79377-44	1.4mm (.055 inch)	Standard Wear
79377-144	1.4mm (.055 inch)	Extended Wear
79377-45	1.8mm (.070 inch)	Standard Wear
79377-145	1.8mm (.070 inch)	Extended Wear
79377-46	1.0mm (.042 inch)	Standard Wear
79377-146	1.0mm (.042 inch)	Extended Wear
79377-47	.7mm (.028 inch)	Standard Wear
79377-147	.7mm (.028 inch)	Extended Wear
79377-48	1.2mm (.047 inch)	Standard Wear
79377-148	1.2mm (.047 inch)	Extended Wear

**FLUID NOZZLE SELECTION
TRANS-TECH. CHART**

Fluid Nozzle Part #	Orifice ID	Nozzle Material
79552-244	1.4mm (.055 inch)	Standard Wear
79552-344	1.4mm (.055 inch)	Extended Wear
79552-245	1.8mm (.070 inch)	Standard Wear
79552-345	1.8mm (.070 inch)	Extended Wear
79552-246	1.0mm (.042 inch)	Standard Wear
79552-346	1.0mm (.042 inch)	Extended Wear
79552-247	.7mm (.028 inch)	Standard Wear
79552-347	.7mm (.028 inch)	Extended Wear
79552-248	1.2mm (.047 inch)	Standard Wear
79552-348	1.2mm (.047 inch)	Extended Wear

AIR CAP / FLUID NOZZLE SELECTION CHART
Air Spray / Trans-Tech. Spray

Air Cap Part #	Fluid Nozzle Part #	Orifice ID	Separate Retaining Ring	Pressure Reducer
79374-65	79377-44	1.4mm (.055)	79379-00	74963-05
79374-65	79377-45	1.8mm (.070)	79379-00	74963-05
79374-98	79377-44	1.4mm (.055)	79379-00	74963-05
79374-98	79377-45	1.8mm (.070)	79379-00	74963-05
79374-122	79552-44	1.4mm (.055)	79379-00	74963-06
79374-122	79552-45	1.8mm (.070)	79379-00	74963-06

NOTES

WARRANTY POLICIES

LIMITED WARRANTY

ITW Ransburg will replace or repair without charge any part and/or equipment that fails within the specified time (see below) because of faulty workmanship or material, provided that the equipment has been used and maintained in accordance with ITW Ransburg's written safety and operating instructions, and has been used under normal operating conditions. Normal wear items are excluded.

THE USE OF OTHER THAN ITW RANSBURG APPROVED PARTS VOID ALL WARRANTIES.

SPARE PARTS: One hundred and eighty (180) days from date of purchase, except for rebuilt parts (any part number ending in "R") for which the warranty period is ninety (90) days.

EQUIPMENT: When purchased as a complete unit, (i.e., guns, power supplies, control units, etc.), is one (1) year from date of purchase. **WRAPPING THE APPLICATOR, ASSOCIATED VALVES AND TUBING, AND SUPPORTING HARDWARE IN PLASTIC, SHRINK-WRAP, OR ANY OTHER NON-APPROVED COVERING, WILL VOID THIS WARRANTY.**

ITW RANSBURG'S ONLY OBLIGATION UNDER THIS WARRANTY IS TO REPLACE PARTS THAT HAVE FAILED BECAUSE OF FAULTY WORKMANSHIP OR MATERIALS. THERE ARE NO IMPLIED WARRANTIES NOR WARRANTIES OF EITHER MERCHANTABILITY OR FITNESS FOR A PARTICULAR PURPOSE. ITW RANSBURG ASSUMES NO LIABILITY FOR INJURY, DAMAGE TO PROPERTY OR FOR CONSEQUENTIAL DAMAGES FOR LOSS OF GOODWILL OR PRODUCTION OR INCOME, WHICH RESULT FROM USE OR MISUSE OF THE EQUIPMENT BY PURCHASER OR OTHERS.

EXCLUSIONS:

If, in ITW Ransburg's opinion the warranty item in question, or other items damaged by this part was improperly installed, operated or maintained, ITW Ransburg will assume no responsibility for repair or replacement of the item or items. The purchaser, therefore, will assume all responsibility for any cost of repair or replacement and service related costs if applicable.

MANUAL CHANGE SUMMARY

This manual was published to supercede Service Manual **AH-08-01.7 Vector Solo Applicators** to make the following changes:

In "Atex/FM" section, the 79943 configuration drawing was updated to reflect the current product offering.

In "Parts Identification" section, the model identification was updated to reflect the current product offering.

In "Parts Identification" section, Table D was updated to reflect current product offering and new round spray part numbers.

Service Manual Price: €40.00 (Euro)
\$50.00 (U.S.)

Manufacturing

1910 North Wayne Street
Angola, Indiana 46703-9100
Telephone: 260/665-8800
Fax: 260/665-8516
www.itwransburg.com

Technical/Service Assistance

Telephone: 800/ 626-3565 Fax: 419/470-2040
Telephone: 800/ 233-3366 Fax: 419/ 470-2071

Technical Support Representative will direct you to the appropriate telephone number for ordering Spare Parts.

